

Avalon Windows & Doors

Toll Free: 888-883-3880

Fax: 832-615-2357

GLASS (FRENCH) DOORS

SIZES :

- WIDTHS: 12" TO 48"
- HEIGHTS: 48" TO 120"
- THICKNESS: 1-3/8" TO 2-1/4"

GLAZING OPTIONS

- 1 LITE INSULTED
- 1 LITE-LOW-E
- 1 LITE-SG
- TDL-SG
- TDL-INSULATED
- TDL-LOW-E
- SDL-INSULATED
- SDL-LOW-E

WOOD SPECIES

- AFRICAN MAHOGANY
- HONDURAS MAHOGANY
- KNOTTY ALDER
- ALDER
- REDOAK
- WHITE OAK
- SOFT MAPLE
- SELECT WHITE MAPLE
- SPANISH CEDAR
- WHITE PINE
- KNOTTY PINE

500 SERIES DOOR

1500-SG

5500-IG

5500E-LOW-E

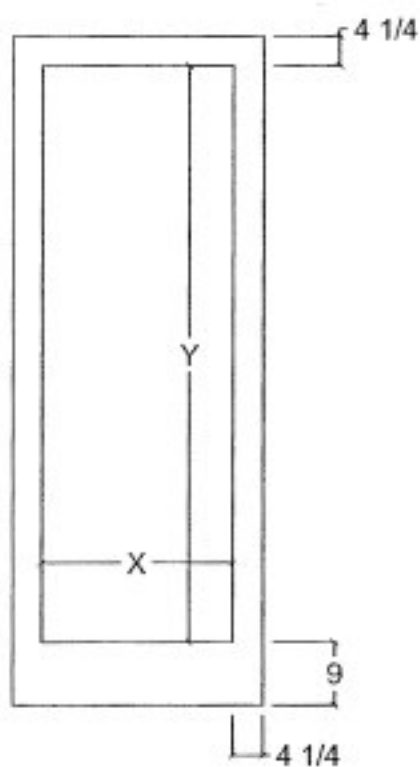

600 SERIES DOOR

1600-SG

5600-IG

5600E-LOW-E

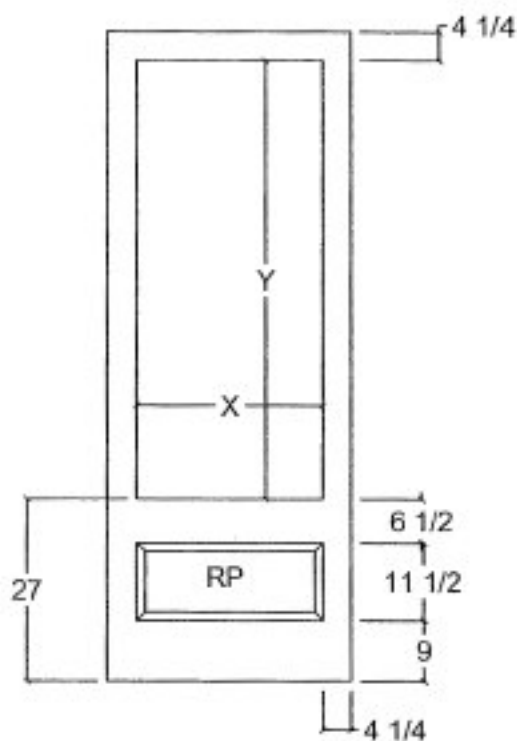

700 SERIES DOOR

1700-SG

5700-IG

5800E-LOW-E

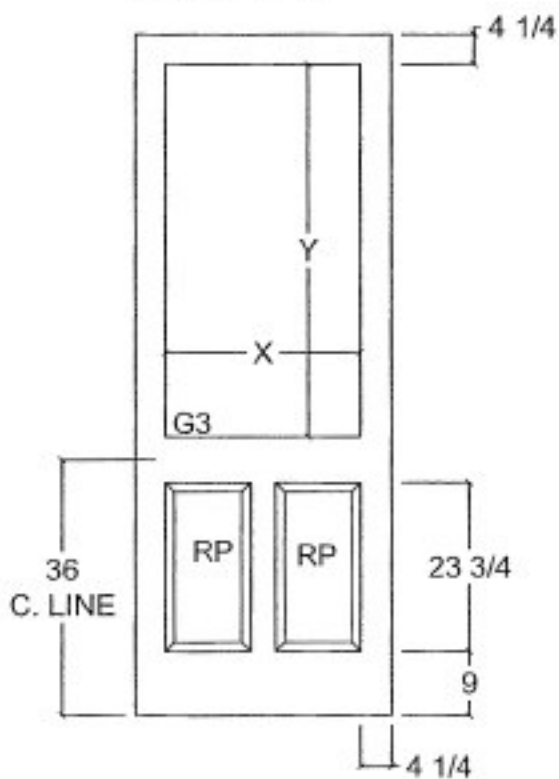

800 SERIES DOOR

1800-SG

5800-IG

5800E-LOW-E

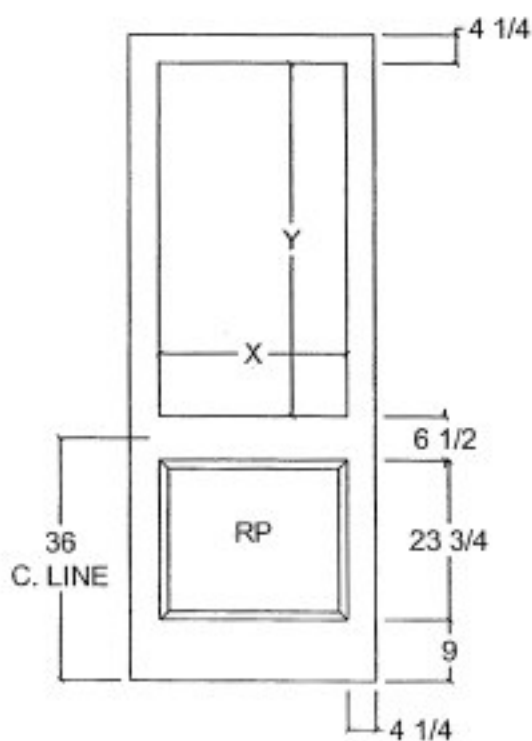

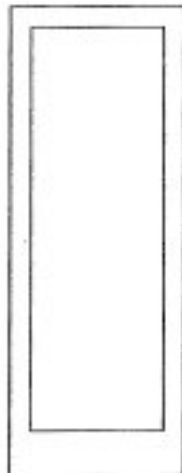

1501-SG
5501-IG
5501E-LOW-E

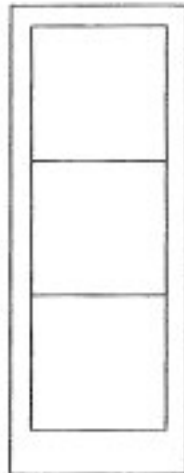

1503-SG
5503-IG
5503E-LOW-E

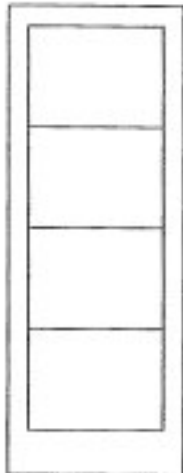

1504-SG
5504-IG
5504E-LOW-E

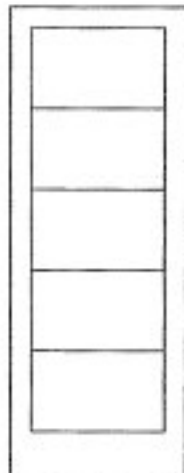

1505-SG
5505-IG
5505E-LOW-E

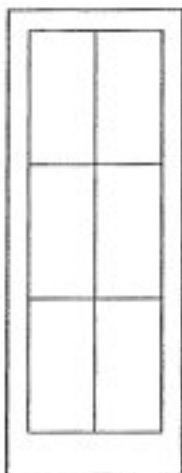

1506-SG
5506-IG
5506E-LOW-E

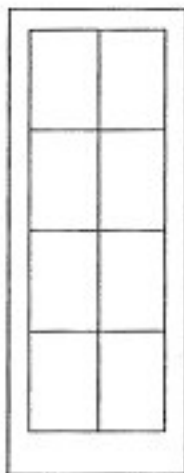

1508-SG
5508-IG
5508E-LOW-E

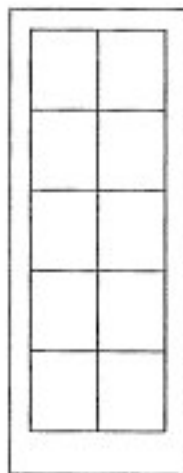

1510-SG
5510-IG
5510E-LOW-E

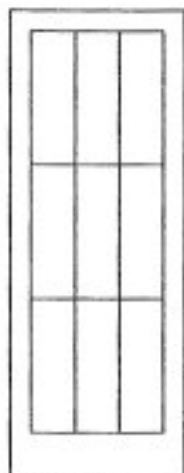

1509-SG
5509-IG
5509E-LOW-E



1512-SG
5512-IG
5512E-LOW-E

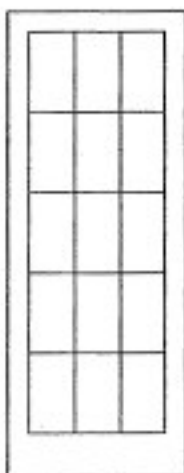

1515-SG
5515-IG
5515E-LOW-E

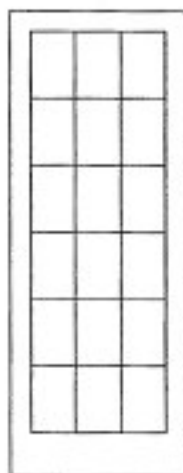

1518-SG
5518-IG
5518E-LOW-E



1509PL-SG
5509PL-IG
5509EPL-LOW-E

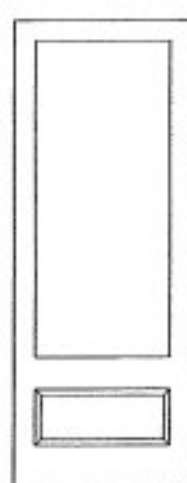

1601-SG
5601-IG
5601E-LOW-E

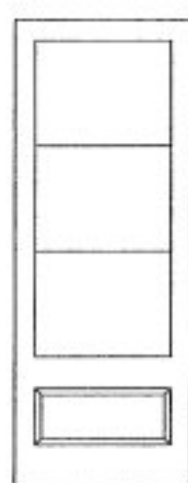

1603-SG
5603-IG
5603E-LOW-E

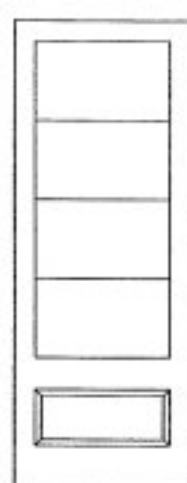

1604-SG
5604-IG
5604E-LOW-E

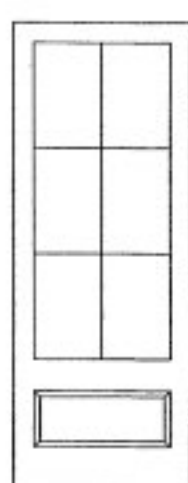

1606-SG
5606-IG
5606E-LOW-E

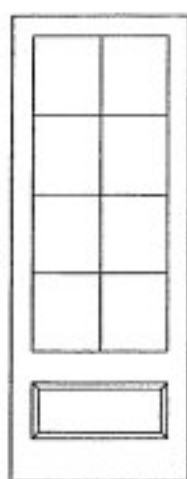

1608-SG
5608-IG
5608E-LOW-E

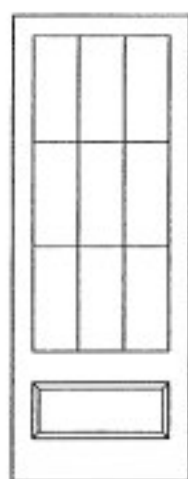

1609-SG
5609-IG
5609E-LOW-E

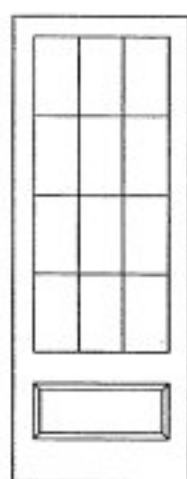

1612-SG
5612-IG
5612E-LOW-E

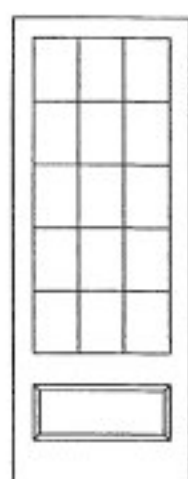

1615-SG
5615-IG
5615E-LOW-E

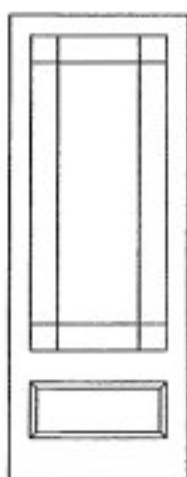

1609PL-SG
5609PL-IG
5609EPL-LOW-E

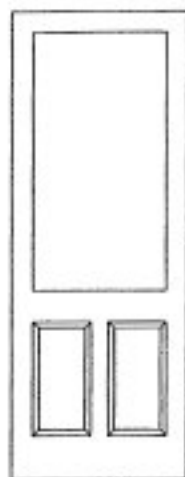

1701-SG
5701-IG
5701E-LOW-E

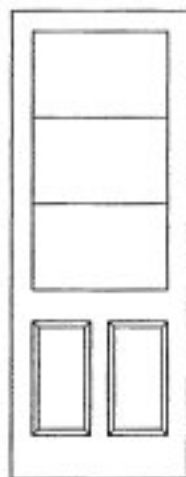

1703-SG
5703-IG
5703E-LOW-E

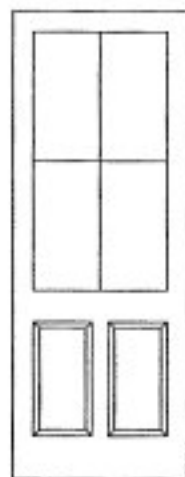

1704-SG
5704-IG
5704E-LOW-E

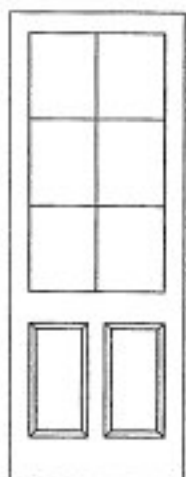

1706-SG
5706-IG
5706E-LOW-E

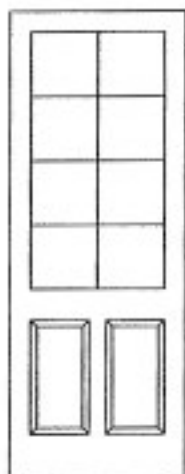

1708-SG
5708-IG
5708E-LOW-E

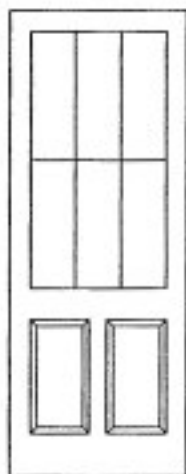

1706-SG
5706-IG
5706E-LOW-E

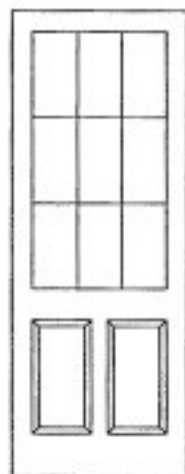

1709-SG
5709-IG
5709E-LOW-E

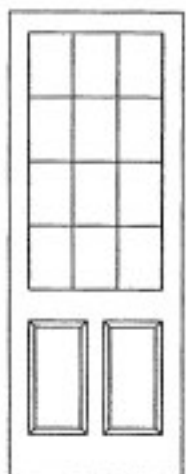

1712-SG
5712-IG
5712E-LOW-E

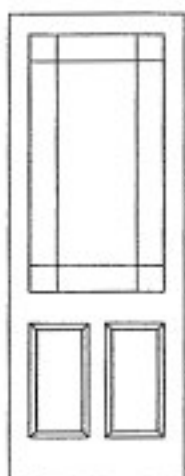

1709PL-SG
5709PL-IG
5709EPL-LOW-E

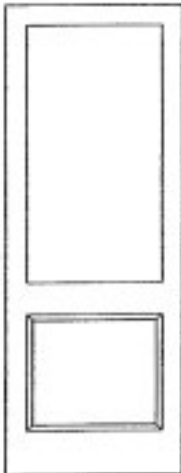

1801-SG
5801-IG
5801E-LOW-E

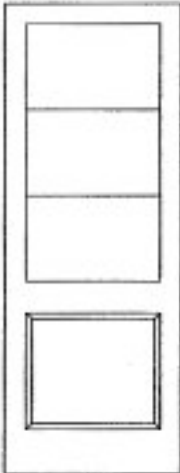

1803-SG
5803-IG
5803E-LOW-E

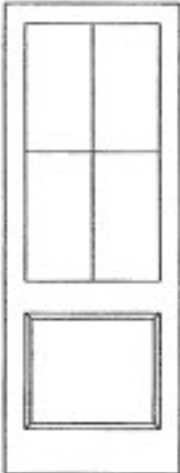

1804-SG
5804-IG
5804E-LOW-E

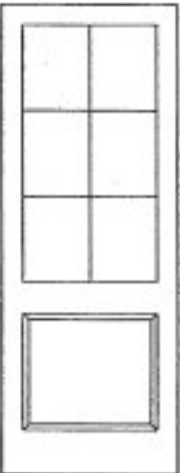

1806-SG
5806-IG
5806E-LOW-E

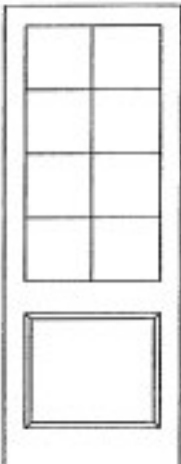

1808-SG
5808-IG
5808E-LOW-E

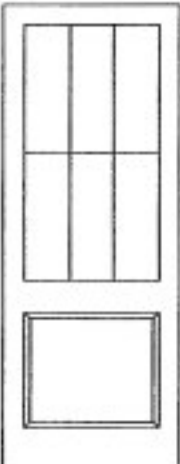

1806-SG
5806-IG
5806E-LOW-E

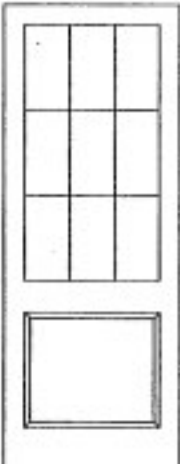

1809-SG
5809-IG
5809E-LOW-E

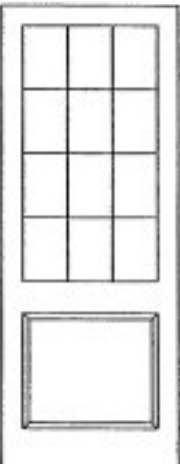

1812-SG
5812-IG
5812E-LOW-E

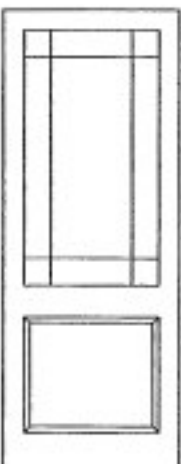

1809PL-SG
5809PL-IG
5809EPL-LOW-E

500A SERIES DOOR

1500A-SG
5500A-IG
5500EA-LOW-E

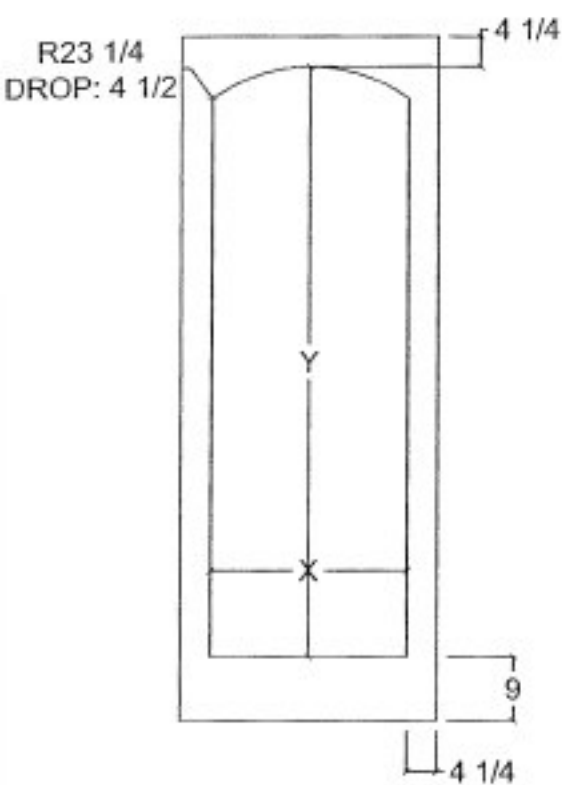

600A SERIES DOOR

1600A-SG
5600A-IG
5600EA-LOW-E

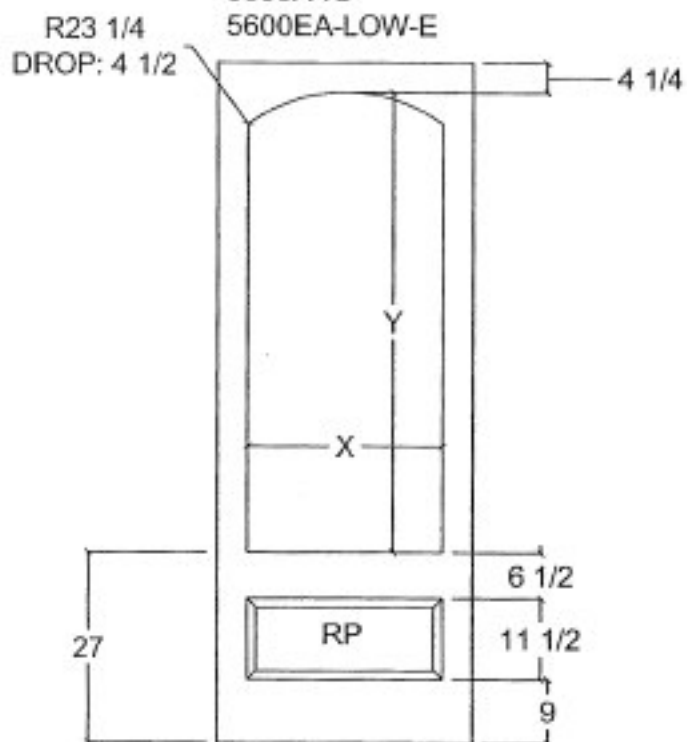

700A SERIES DOOR

1700A-SG
5700A-IG
5700EA-LOW-E

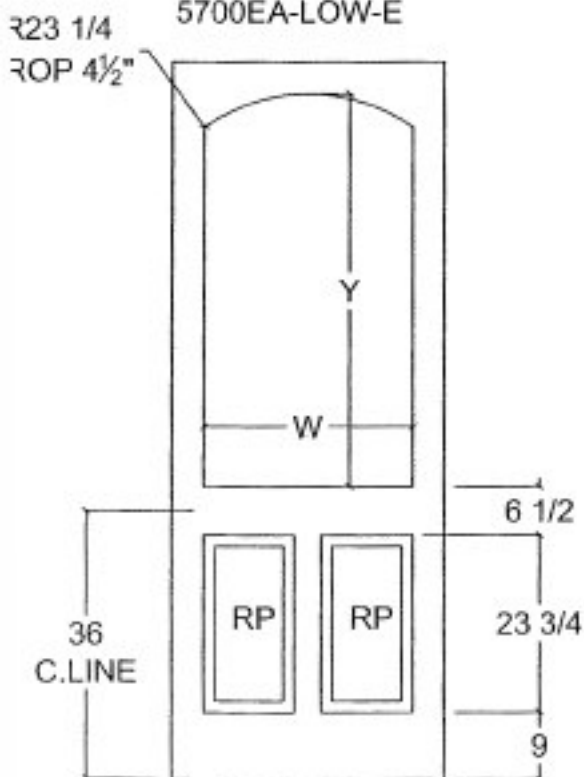

800A SERIES DOOR

1800A-SG
5800A-IG
5800EA-LOW-E

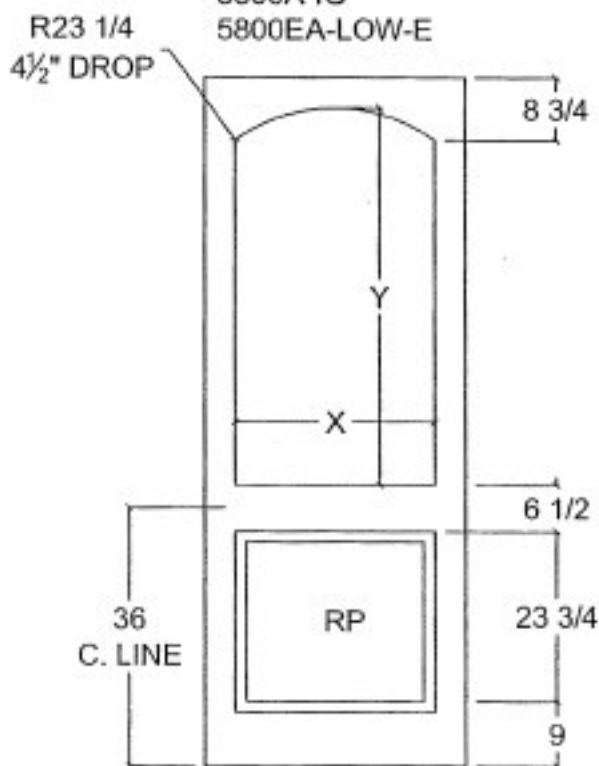

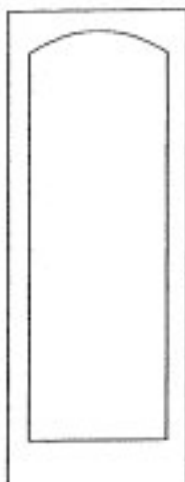

1501A-SG
5501A-IG
5501EA-LOW-E

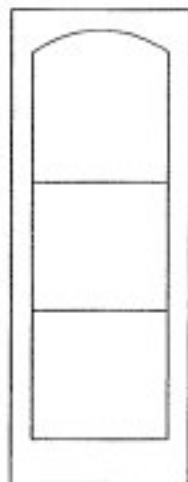

1503A-SG
5503A-IG
5503EA-LOW-E

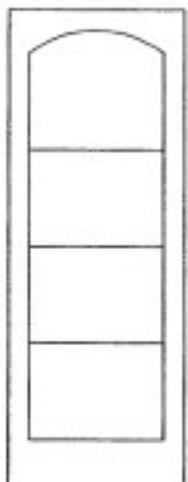

1504A-SG
5504A-IG
5504EA-LOW-E

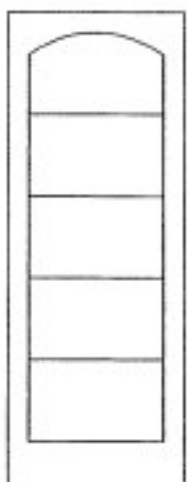

1505A-SG
5505A-IG
5505EA-LOW-E

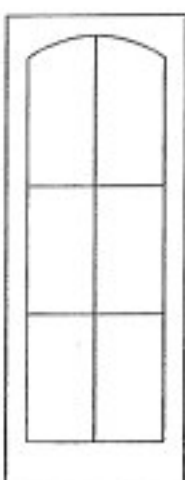

1506A-SG
5506A-IG
5506EA-LOW-E

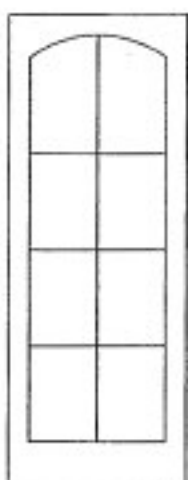

1508A-SG
5508A-IG
5508EA-LOW-E

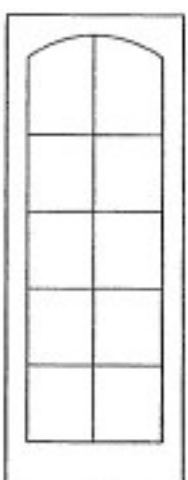

1510A-SG
5510A-IG
5510EA-LOW-E

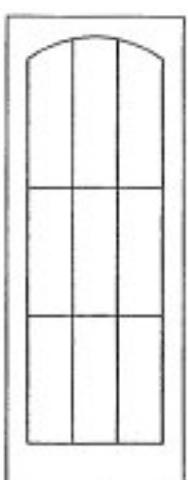

1509A-SG
5509A-IG
5509EA-LOW-E

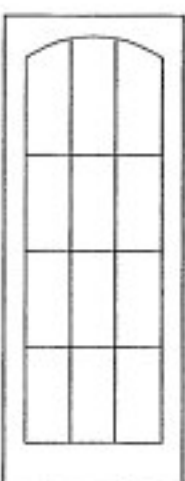

1512A-SG
5512A-IG
5512EA-LOW-E



1515A-SG
5515A-IG
5515EA-LOW-E

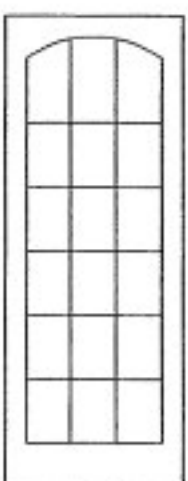

1518A-SG
5518A-IG
5518EA-LOW-E



1509APL-SG
5509APL-IG
5509EAPL-LOW-E



1601A-SG
5601A-IG
5601EA-LOW-E

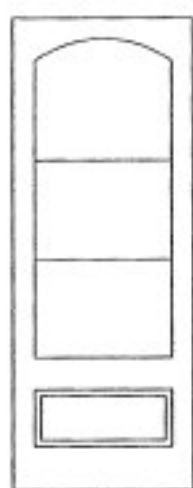

1603A-SG
5603A-IG
5603EA-LOW-E

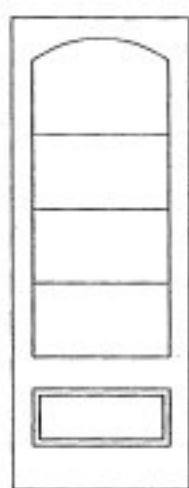

1604A-SG
5604A-IG
5604EA-LOW-E

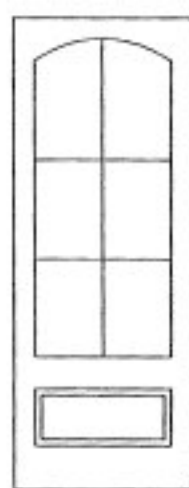

1606A-SG
5606A-IG
5606EA-LOW-E



1608A-SG
5608A-IG
5608EA-LOW-E

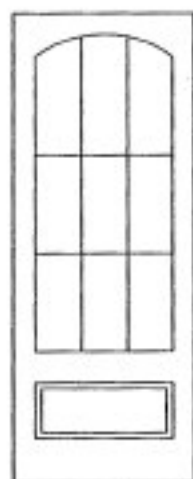

1609A-SG
5609A-IG
5609EA-LOW-E

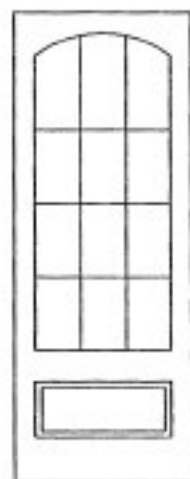

1612A-SG
5612A-IG
5612EA-LOW-E

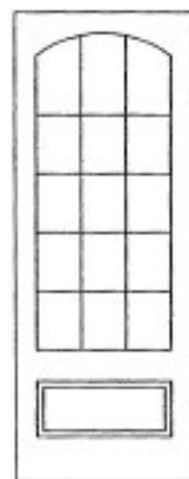

1615A-SG
5615A-IG
5615EA-LOW-E

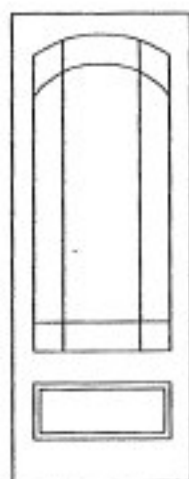

1609APL-SG
5609APL-IG
5609EAPL-LOW-E

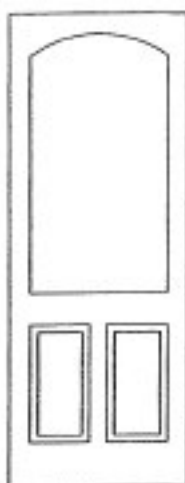

1701A-SG
5701A-IG
5701EA-LOW-E

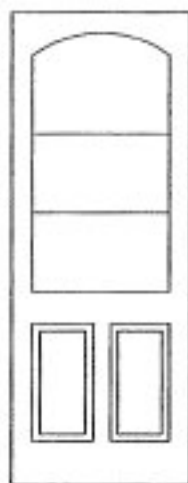

1703A-SG
5703A-IG
5703EA-LOW-E

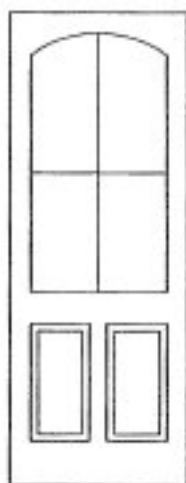

1704A-SG
5704A-IG
5704EA-LOW-E

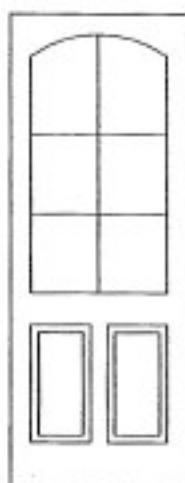

1706A-SG
5706A-IG
5706EA-LOW-E

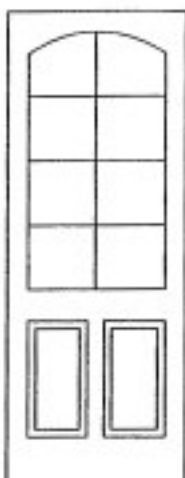

1708A-SG
5708A-IG
5708EA-LOW-E

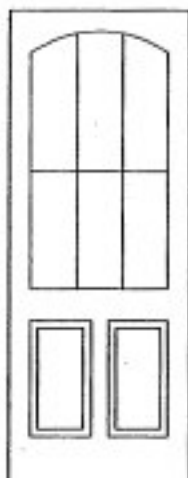

1706A-SG
5706A-IG
5706EA-LOW-E

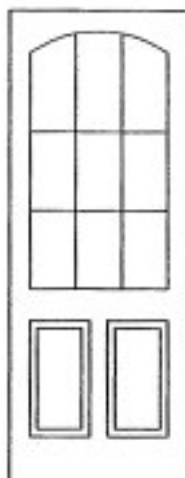

1709A-SG
5709A-IG
5709EA-LOW-E

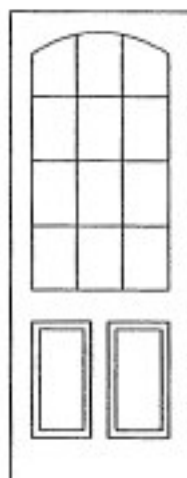

1712A-SG
5712A-IG
5712EA-LOW-E

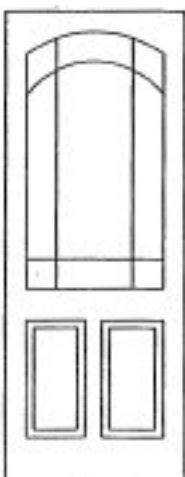

1709APL-SG
5709APL-IG
5709EAPL-LOW-E

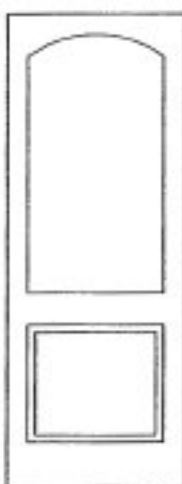

1801A-SG
5801A-IG
5801EA-LOW-E

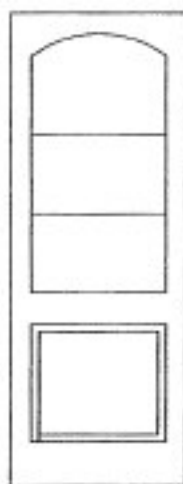

1803A-SG
5803A-IG
5803EA-LOW-E

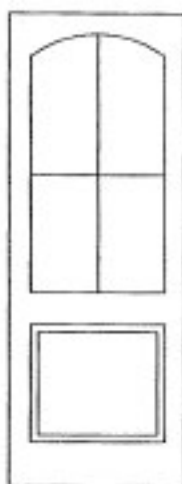

1806A-SG
5806A-IG
5806EA-LOW-E

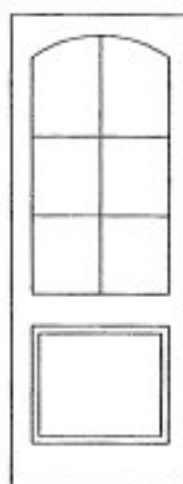

1806A-SG
5806A-IG
5806EA-LOW-E

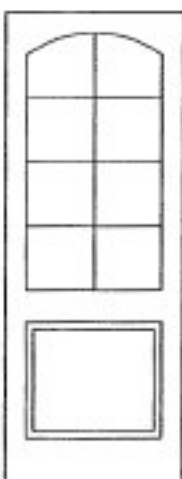

1808A-SG
5808A-IG
5808EA-LOW-E

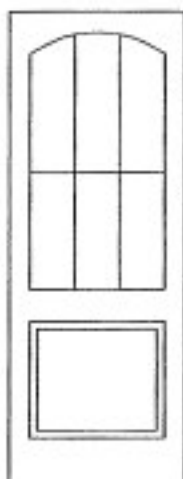

1806A-SG
5806A-IG
5806EA-LOW-E

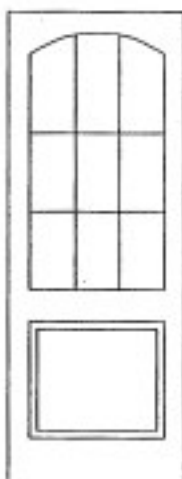

1809A-SG
5809A-IG
5809EA-LOW-E

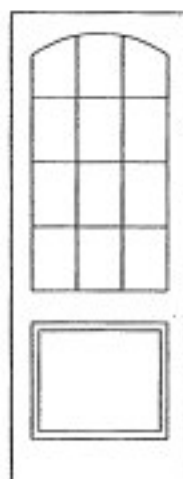

1812A-SG
5812A-IG
5812EA-LOW-E

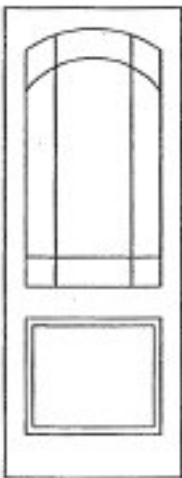

1809APL-SG
5809APL-IG
5809AEPL-LOW-E

500H SERIES DOOR

1500H-SG

5500H-IG

5500EH-LOW-E

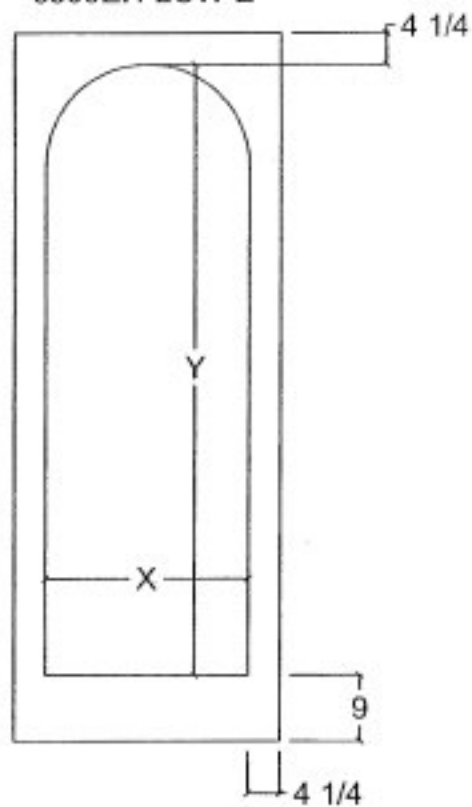

600H SERIES DOOR

1600H-SG

5600H-IG

5600EH-LOW-E

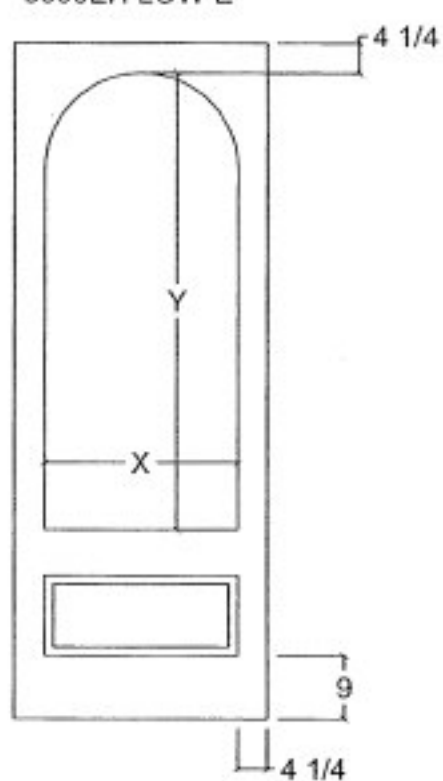

700A SERIES DOOR

1700A-SG

5700A-IG

5700EA-LOW-E

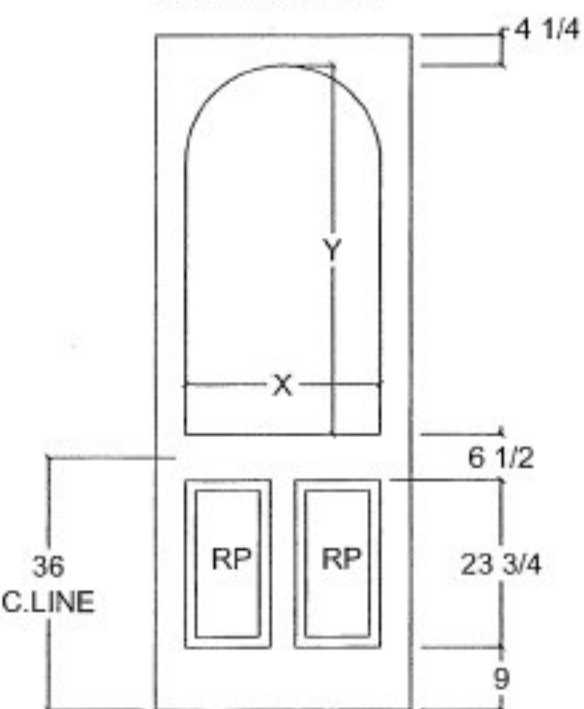

800H SERIES DOOR

1800H-SG

5800H-IG

5800EH-LOW-E

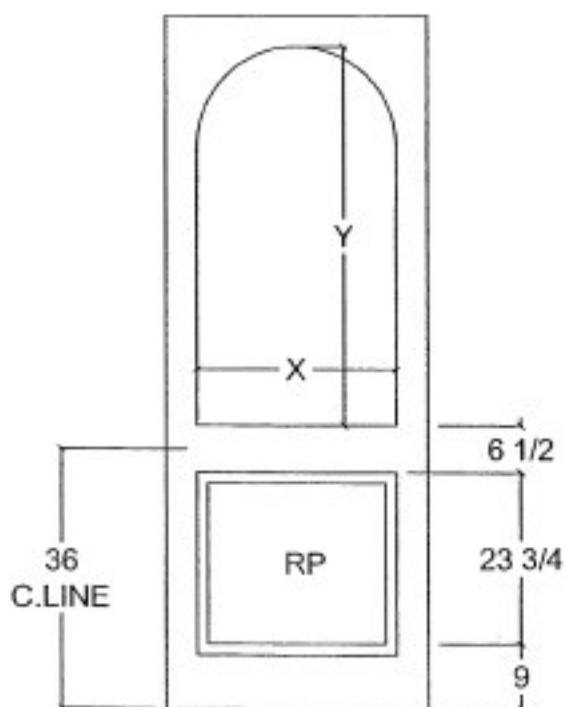



1501H-SG
5501H-IG
5501EH-LOW-E

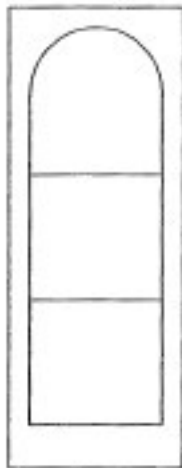

1503H-SG
5503H-IG
5503EH-LOW-E

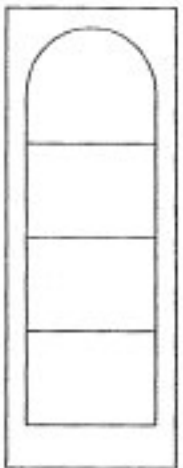

1504H-SG
5504H-IG
5504EH-LOW-E

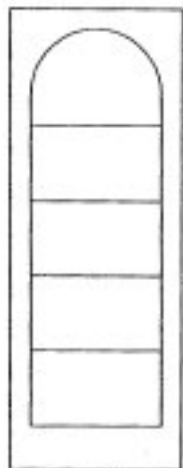

1505H-SG
5505H-IG
5505EH-LOW-E



1506H-SG
5506H-IG
5506EH-LOW-E

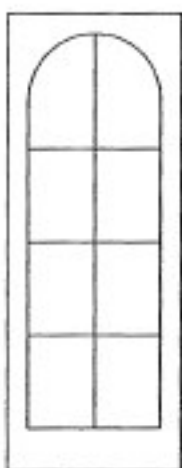

1508H-SG
5508H-IG
5508EH-LOW-E



1510H-SG
5510H-IG
5510EH-LOW-E

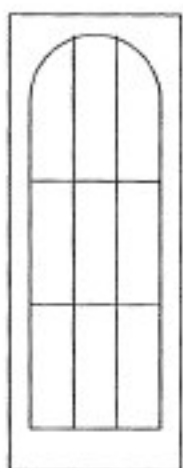

1506H-SG
5506H-IG
5506EH-LOW-E

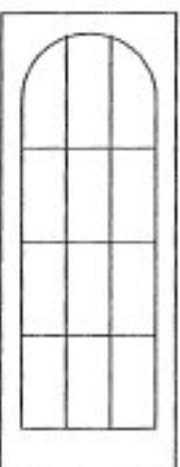

1512H-SG
5512H-IG
5512EH-LOW-E



1515H-SG
5515H-IG
5515EH-LOW-E

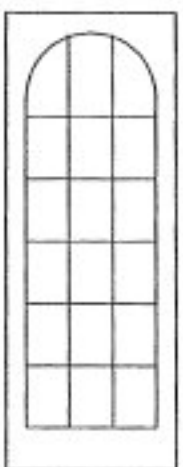

1518H-SG
5518H-IG
5518EH-LOW-E



1501HPL-SG
5501HPL-IG
5501EHPL-LOW-E



1601H-SG
5601H-IG
5601EH-LOW-E

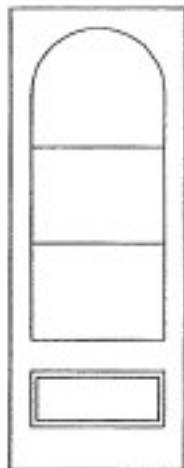

1603H-SG
5603H-IG
5603EH-LOW-E

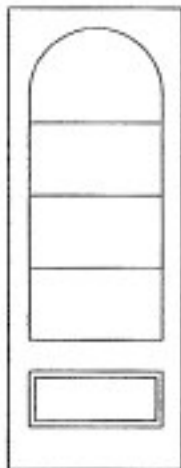

1604H-SG
5604H-IG
5604EH-LOW-E

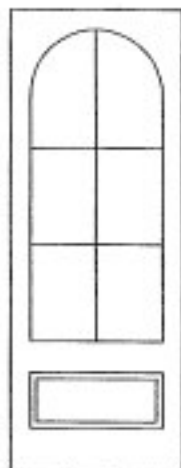

1606H-SG
5606H-IG
5606EH-LOW-E



1608H-SG
5608H-IG
5608EH-LOW-E



1609H-SG
5609H-IG
5609EH-LOW-E

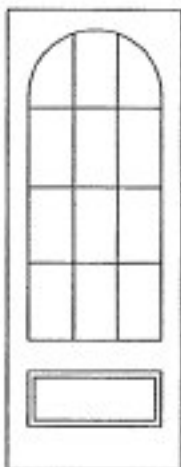

1612H-SG
5612H-IG
5612EH-LOW-E

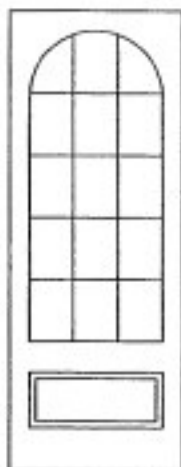

1612H-SG
5612H-IG
5612EH-LOW-E

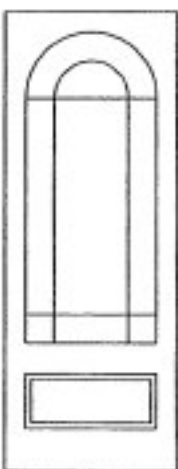

1601H-SG
5601H-IG
5601EH-LOW-E

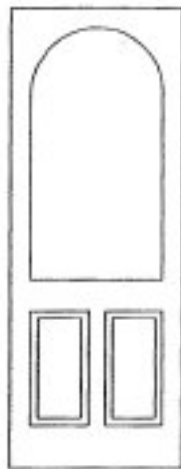

1701H-SG
5701H-IG
5701EH-LOW-E

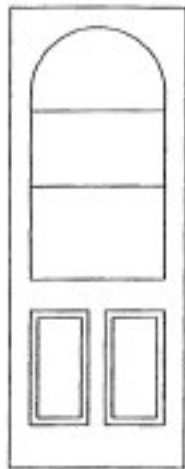

1701H-SG
5701H-IG
5701EH-LOW-E

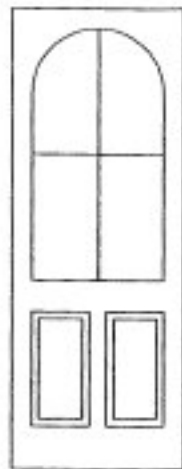

1704H-SG
5704H-IG
5704EH-LOW-E

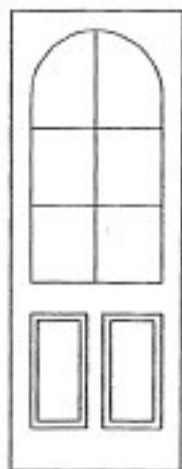

1706H-SG
5706H-IG
5706EH-LOW-E

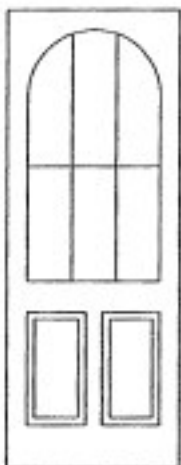

1706H-SG
5706H-IG
5706EH-LOW-E

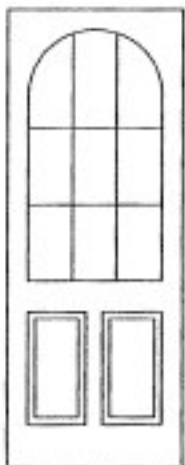

1709H-SG
5709H-IG
5709EH-LOW-E

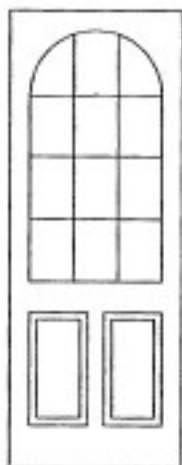

1712H-SG
5712H-IG
5712EH-LOW-E

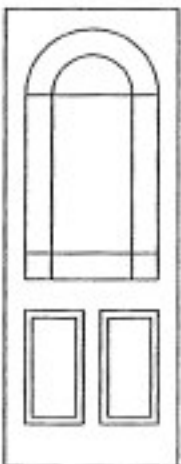

1709HPL-SG
5709HPL-IG
5709EHPL-LOW-E



1801H-SG
5801H-IG
5801EH-LOW-E

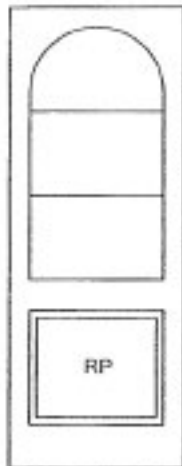

1803H-SG
5803H-IG
5803EH-LOW-E

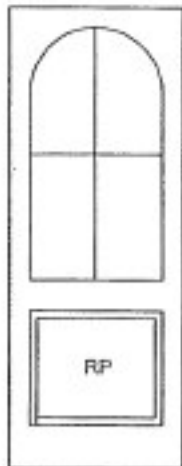

1804H-SG
5804H-IG
5804EH-LOW-E

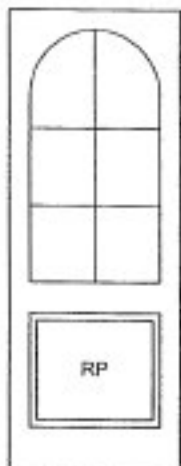

1806H-SG
5806H-IG
5806EH-LOW-E

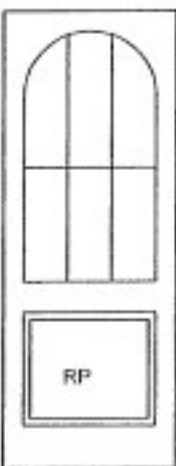

1806H-SG
5806H-IG
5806EH-LOW-E

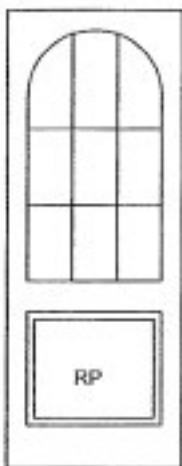

1809H-SG
5809H-IG
5809EH-LOW-E

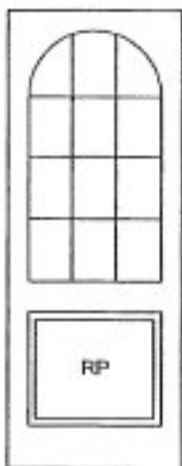

1812H-SG
5812H-IG
5812EH-LOW-E

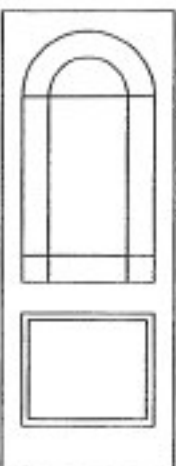

1809HPL-SG
5809HPL-IG
5809EHPL-LOW-E

A500 SERIES DOOR

A1500-SG

A5500-IG

A5500E-LOW-E

R27 1/2
4 1/2 DROP

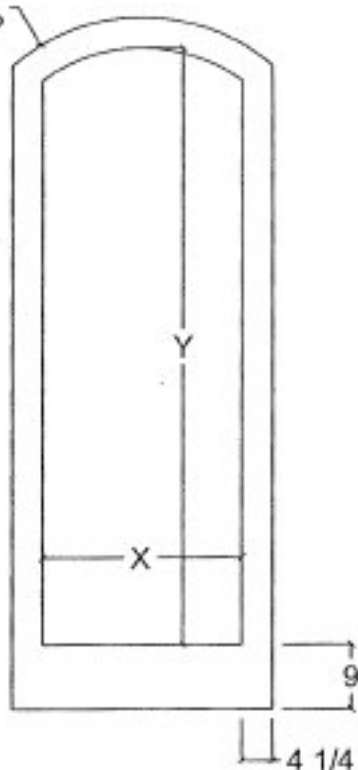

A600 SERIES DOOR

A1600-SG

A5600-IG

A5600E-LOW-E

R27 1/2
DROP: 4 1/2

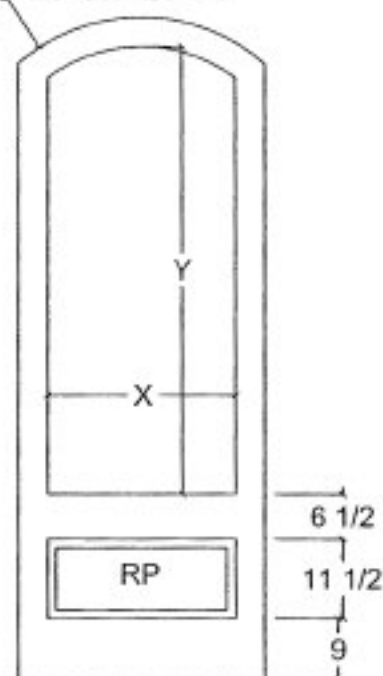

A700 SERIES DOOR

A1700-SG

A5700-IG

A5700E-LOW-E

R27 1/2
1 1/2" DROP

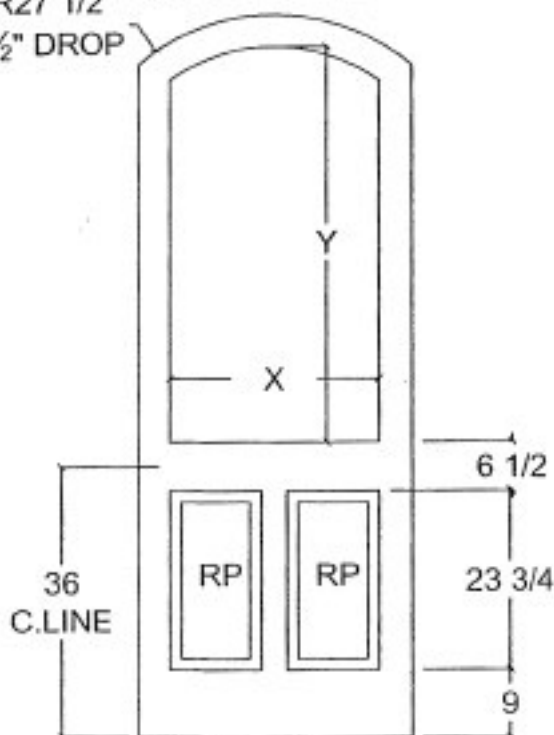

A800 SERIES DOOR

A1800-SG

A5800-IG

A5800E-LOW-E

R23 1/4
DROP: 4 1/2

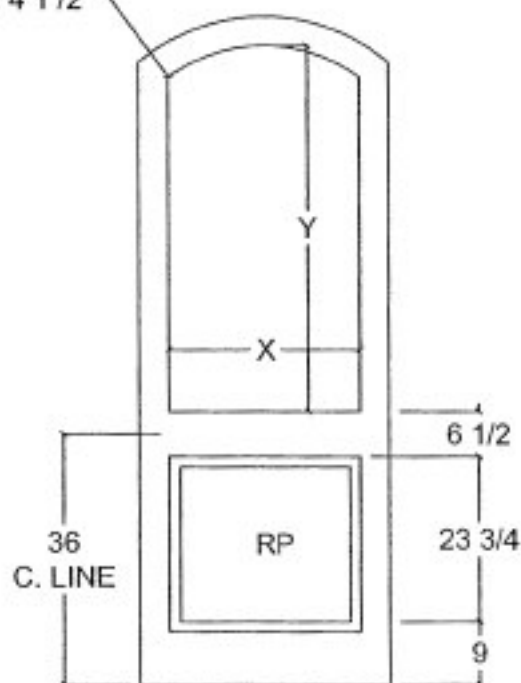

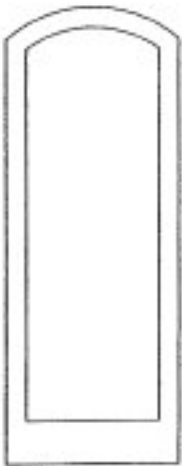

A1501-SG
A5501-IG
A5501E-LOW-E

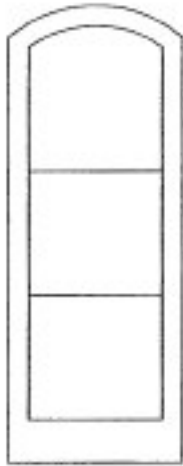

A1503-SG
A5503-IG
A5503E-LOW-E



A1504-SG
A5504-IG
A5504E-LOW-E

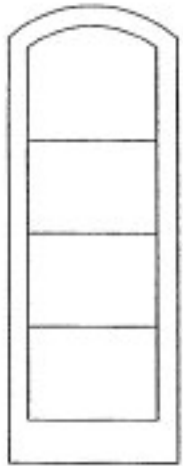

A1504-SG
A5504-IG
A5504E-LOW-E

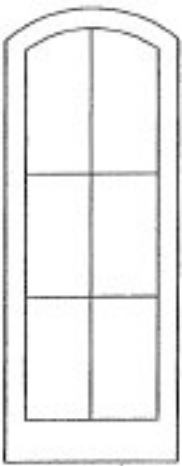

A1506-SG
A5506-IG
A5506E-LOW-E

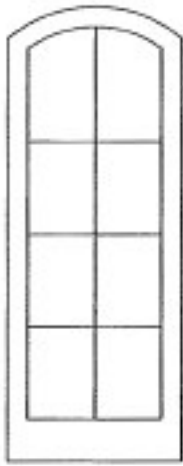

A1508-SG
A5508-IG
A5508E-LOW-E

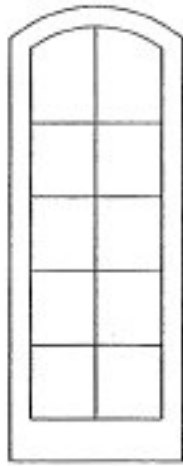

A1510-SG
A5510-IG
A5510E-LOW-E

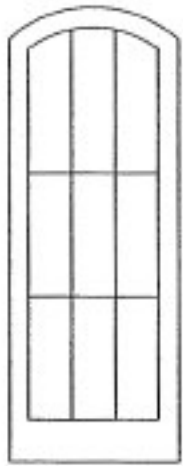

A1509-SG
A5509-IG
A5509E-LOW-E

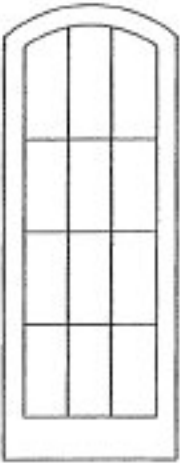

A1512-SG
A5512-IG
A5512E-LOW-E

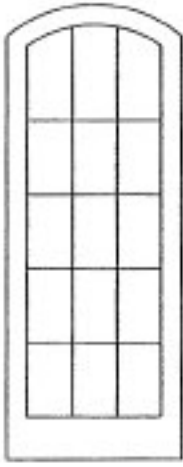

A1515-SG
A5515-IG
A5515E-LOW-E

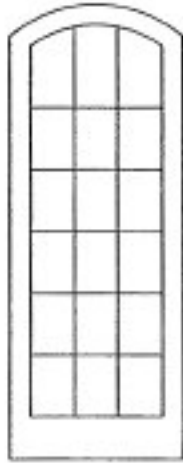

A1518-SG
A5518-IG
A5518E-LOW-E

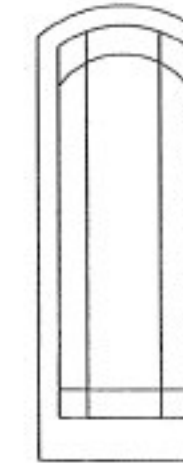

A1509PL-SG
A5509PL-IG
A5509EPL-LOW-E

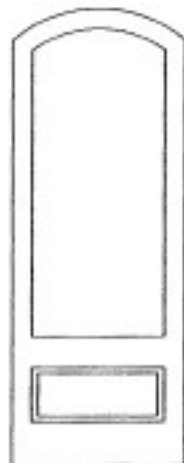

A1601-SG
A5601-IG
A5601E-LOW-E

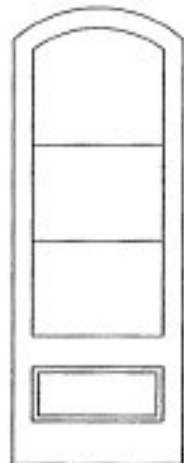

A1603-SG
A5603-IG
A5603E-LOW-E

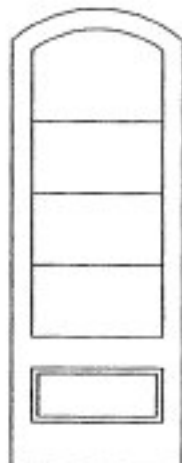

A1604-SG
A5604-IG
A5604A-LOW-E

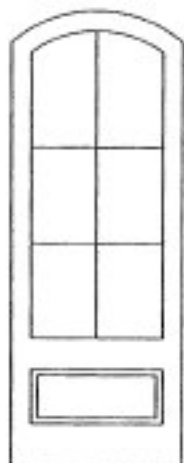

A1608-SG
A5608-IG
A5608E-LOW-E

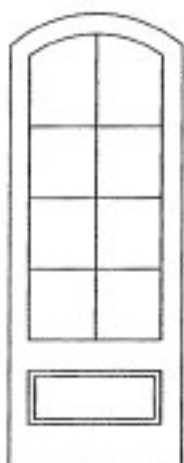

A1608-SG
A5608-IG
A5608E-LOW-E

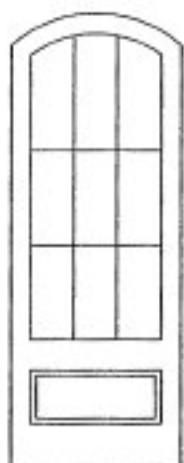

A1609-SG
A5609-IG
A5609E-LOW-E

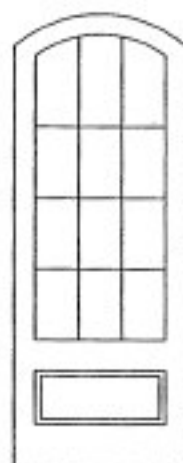

A1612-SG
A5612-IG
A5612E-LOW-E

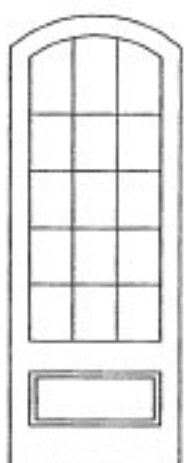

A1615-SG
A5615-IG
A5615E-LOW-E



A1609PL-SG
A5609PL-IG
A5609EPL-LOW-E

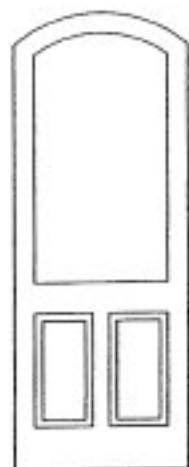

A1701-SG
A5701-IG
A5701E-LOW-E

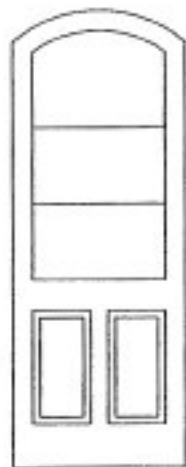

A1703-SG
A5703-IG
A5703E-LOW-E

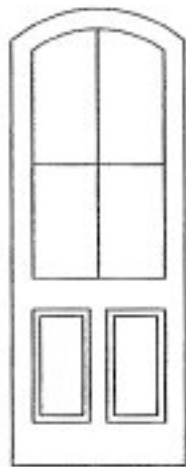

A1704-SG
A5704-IG
A5704E-LOW-E

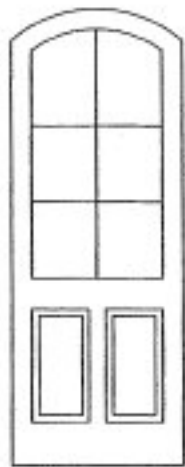

A1706-SG
A5706-IG
A5706E-LOW-E

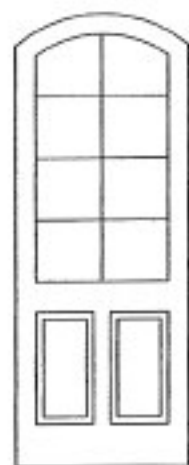

A1708-SG
A5708-IG
A5708E-LOW-E

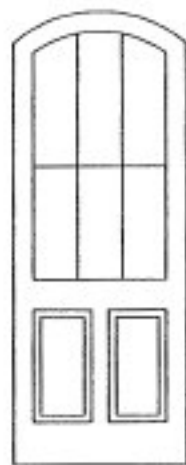

A1706-SG
A5706-IG
A5706E-LOW-E

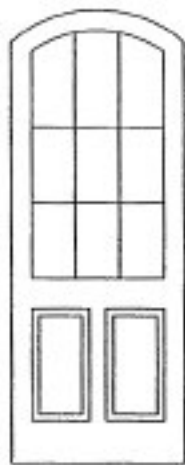

A1709-SG
A5709-IG
A5709E-LOW-E

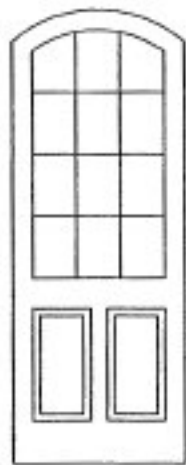

A1712-SG
A5712-IG
A5712E-LOW-E

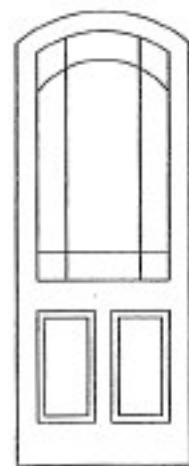

A1709PL-SG
A5709PL-IG
A5709EPL-LOW-E

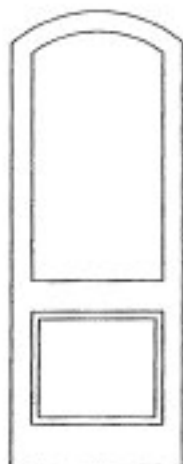

A1801-SG
A5801-IG
A5801E-LOW-E

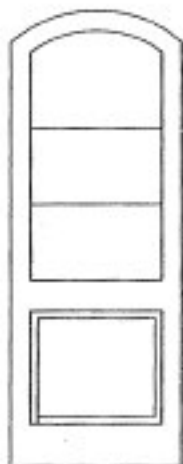

A1803-SG
A5803-IG
A5803E-LOW-E

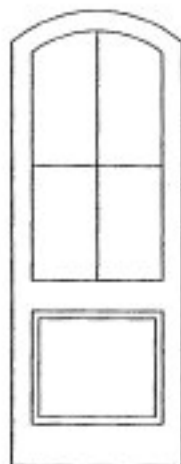

A1806-SG
A5806-IG
A5806E-LOW-E

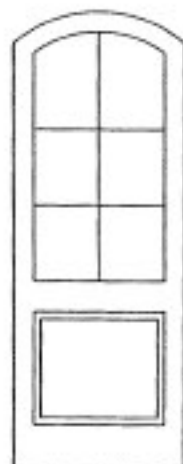

A1806-SG
A5806-IG
A5806E-LOW-E

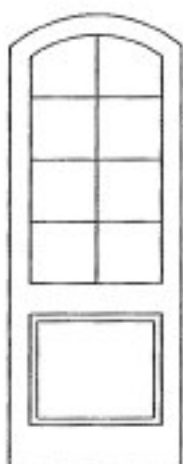

A1808-SG
A5808-IG
A5808E-LOW-E

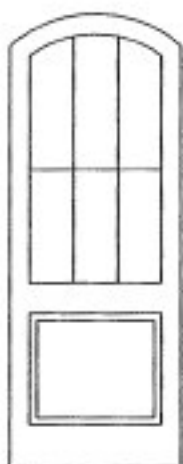

A1806-SG
A5806-IG
A5806E-LOW-E

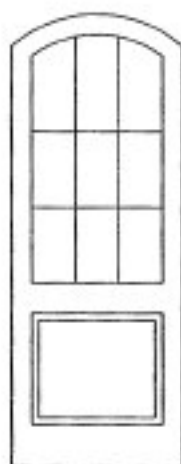

A1809-SG
A5809-IG
A5809E-LOW-E

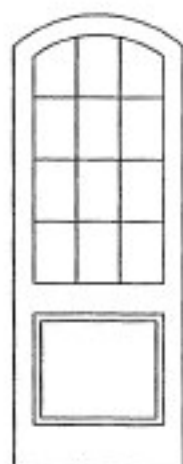

A1812-SG
A5812-IG
A5812E-LOW-E

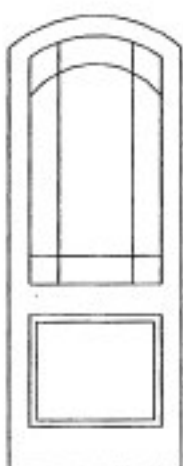

A1809PL-SG
A5809PL-IG
A5809AEPL-LOW-E

H500 SERIES DOOR

H1500-SG

H5500-IG

H5500E-LOW-E

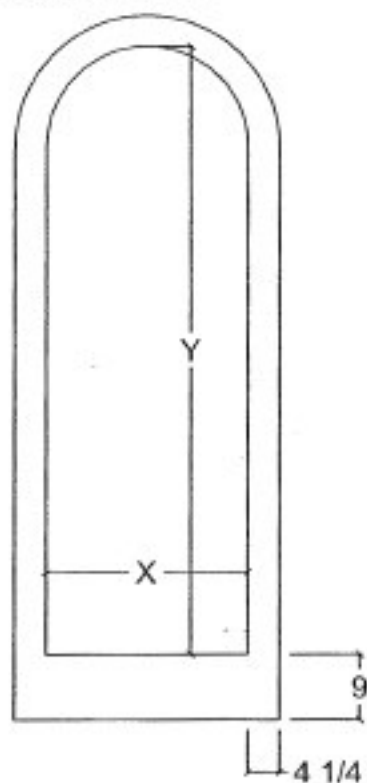

H600 SERIES DOOR

H1600-SG

H5600-IG

H5600E-LOW-E

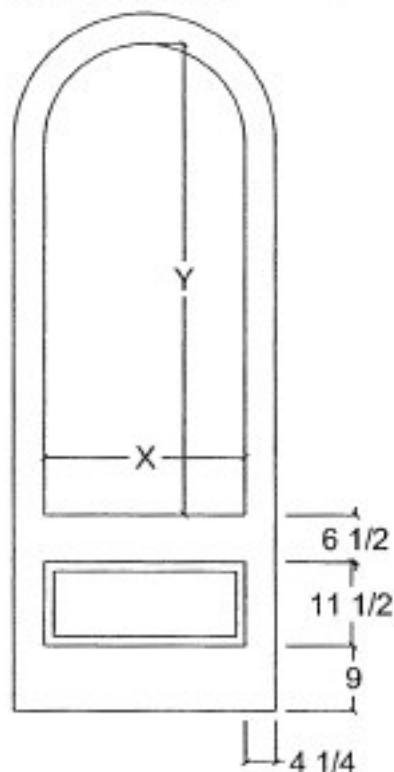

H700 SERIES DOOR

H1700-SG

H5700-IG

H5700E-LOW-E

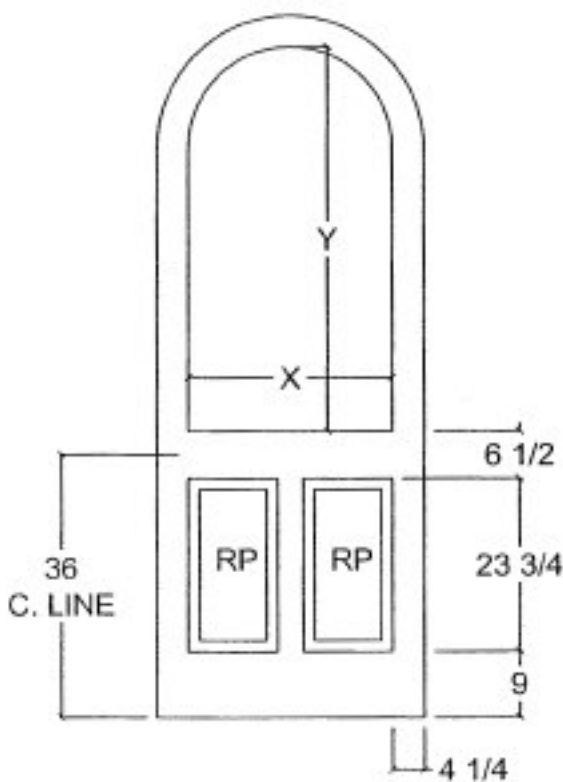

H800 SERIES DOOR

H1800-SG

H5800-IG

H5800E-LOW-E

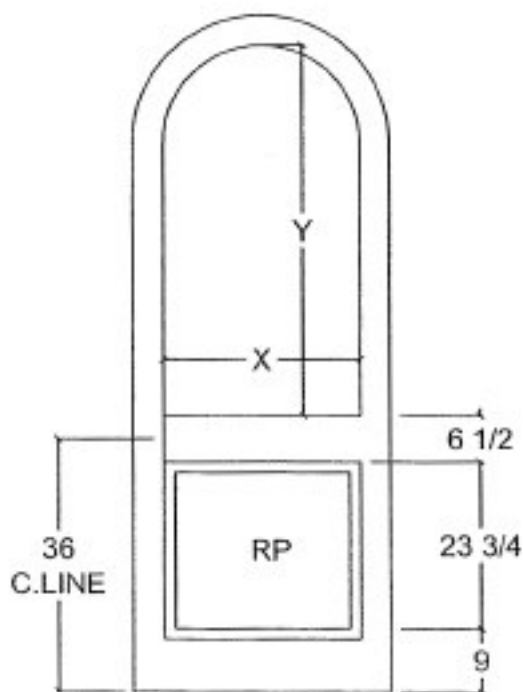

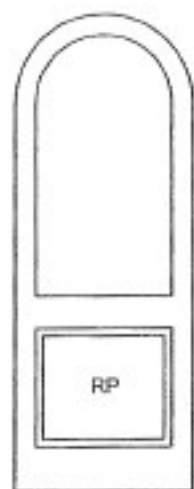

H1801-SG
H5801-IG
H5801E-LOW-E

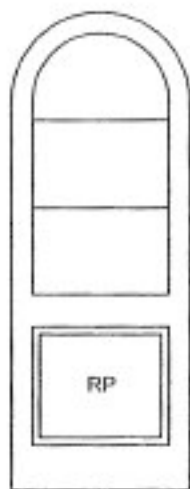

H1803-SG
H5803-IG
H5803E-LOW-E

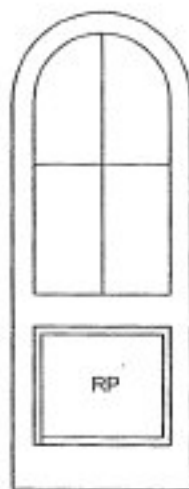

H1804-SG
H5804-IG
H5804E-LOW-E

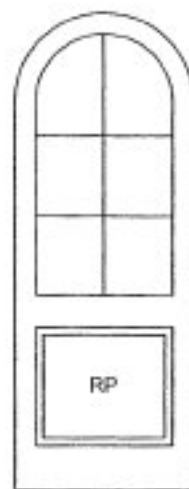

H1806-SG
H5806-IG
H5806E-LOW-E

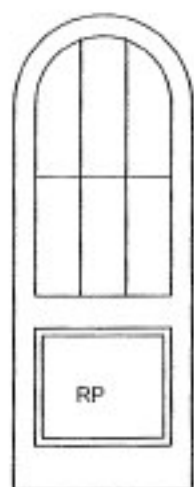

H1806-SG
H5806-IG
H5806E-LOW-E

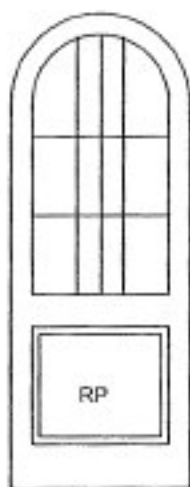

H1809-SG
H5809-IG
5809E-LOW-E

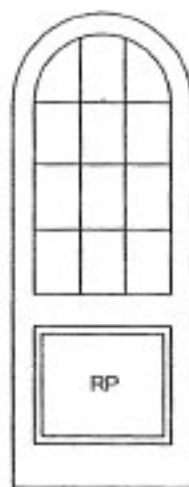

1812H-SG
5812H-IG
5812EH-LOW-E

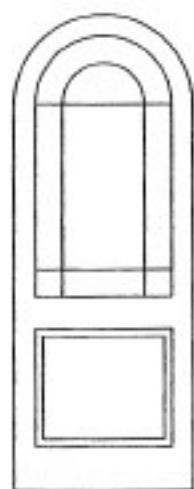

H1809PL-SG
H5809PL-IG
5809EPL-LOW-E



H1601-SG
H5601-IG
H5601E-LOW-E

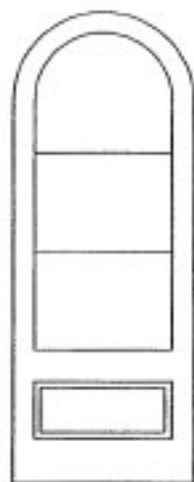

H1603-SG
H5603-IG
H5603E-LOW-E

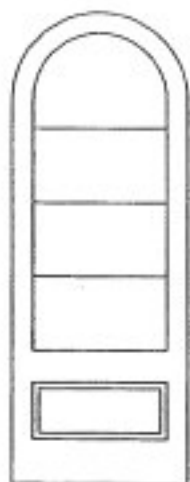

H1604-SG
H5604-IG
H5604E-LOW-E

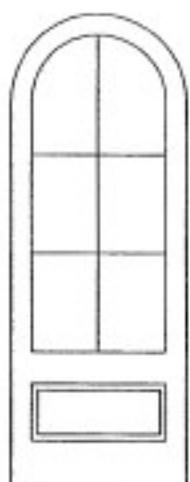

H1606-SG
H5606-IG
H5606E-LOW-E



H1608-SG
H5608-IG
H5608E-LOW-E



H1609-SG
H5609-IG
H5609E-LOW-E

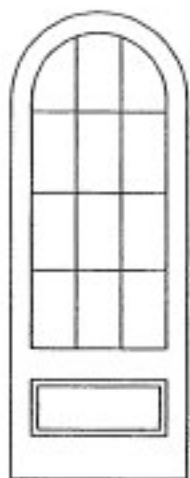

H1612-SG
H5612-IG
H5612E-LOW-E

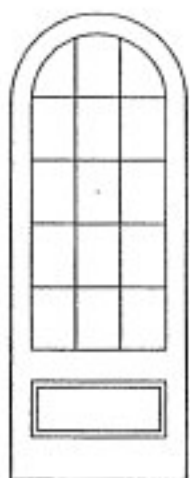

H1612-SG
H5612-IG
H5612E-LOW-E

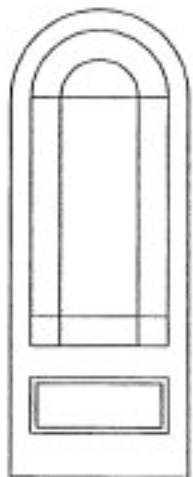

H1601-SG
H5601-IG
H5601E-LOW-E

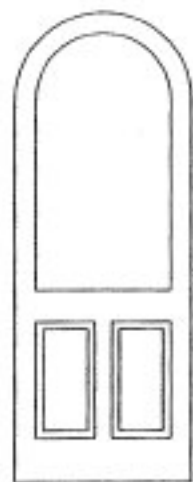

H1701-SG
H5701-IG
H5701E-LOW-E

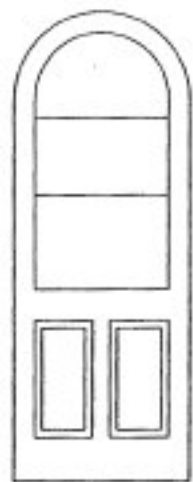

H1701-SG
H5701-IG
H5701E-LOW-E

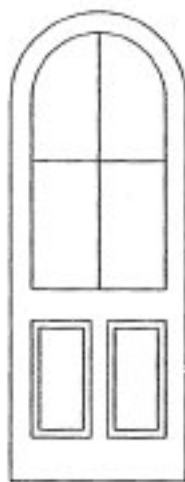

H1704-SG
H5704-IG
H5704E-LOW-E

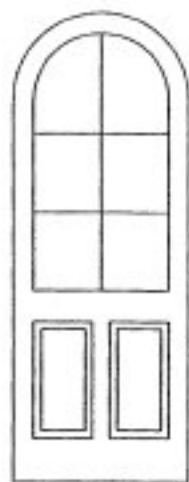

H1706-SG
H5706-IG
H5706E-LOW-E

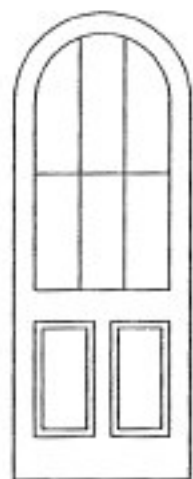

H1706-SG
H5706-IG
H5706E-LOW-E

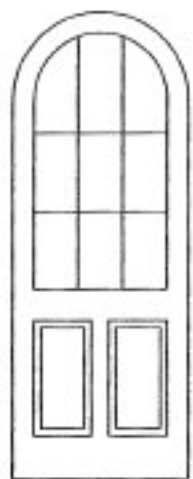

H1709-SG
H5709-IG
H5709E-LOW-E

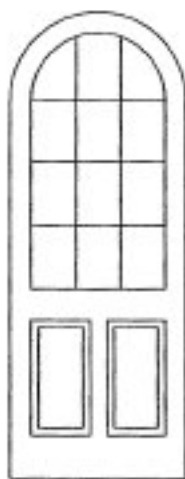

H1712H-SG
H5712-IG
H5712E-LOW-E

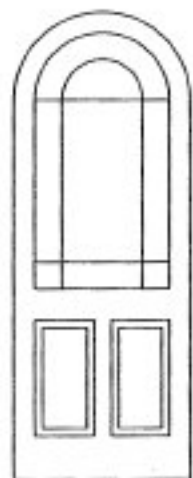

H1709PL-SG
H5709PL-IG
H5709EPL-LOW-E

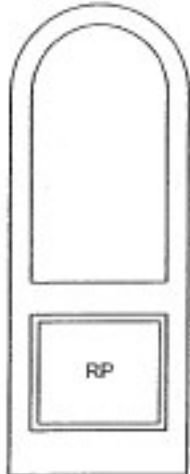

H1801-SG
H5801-IG
H5801E-LOW-E

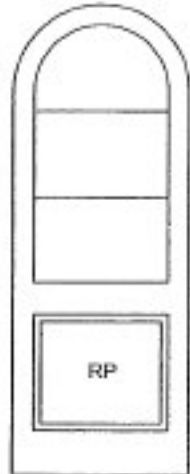

H1803-SG
H5803-IG
H5803E-LOW-E

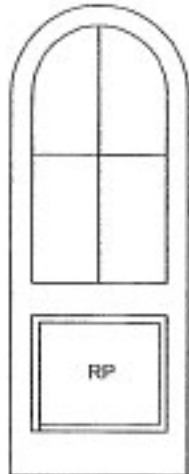

H1804-SG
H5804-IG
H5804E-LOW-E

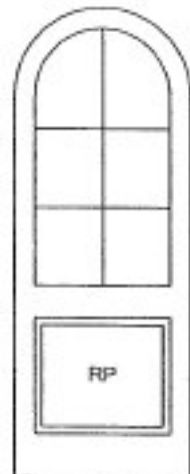

H1806-SG
H5806-IG
H5806E-LOW-E

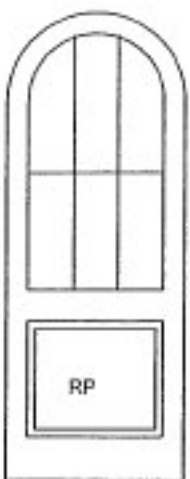

H1806-SG
H5806-IG
H5806E-LOW-E

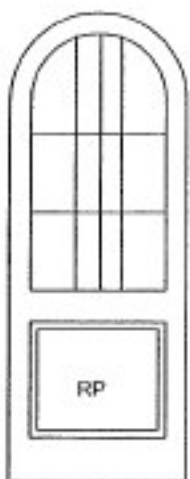

H1809-SG
H5809-IG
5809E-LOW-E

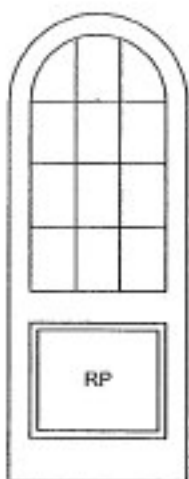

1812H-SG
5812H-IG
5812EH-LOW-E

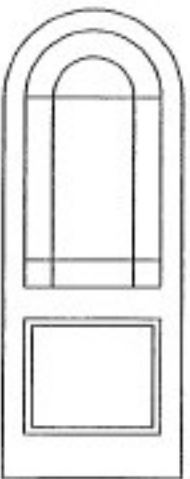

H1809PL-SG
H5809PL-IG
5809EPL-LOW-E

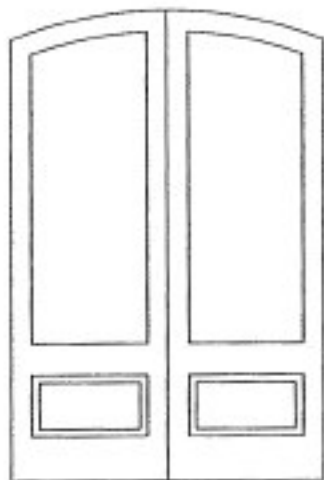

A1601-PR-SG
A5601-PR-IG
A5601-PR-LOW-E

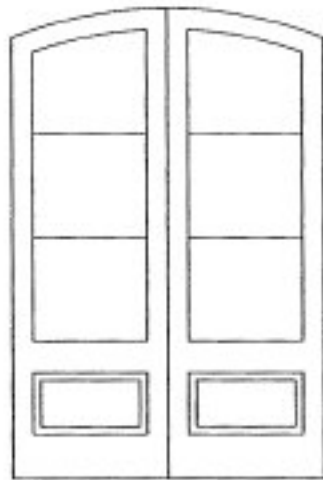

A1603-PR-SG
A5603-PR-IG
A5603-PR-LOW-E

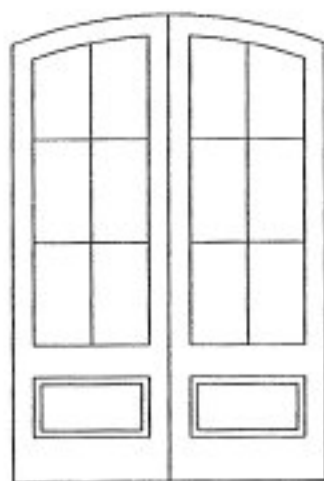

A1606-PR-SG
A5606-PR-IG
A5606-PR-LOW-E

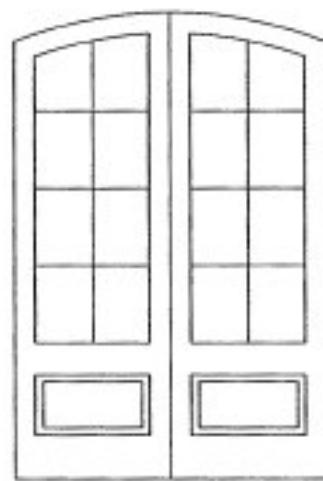

A1608-PR-SG
A5608-PR-IG
A5608-PR-LOW-E

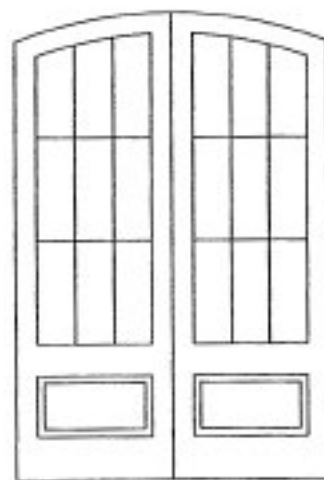

A1609-PR-SG
A5609-PR-IG
A5609-PR-LOW-E

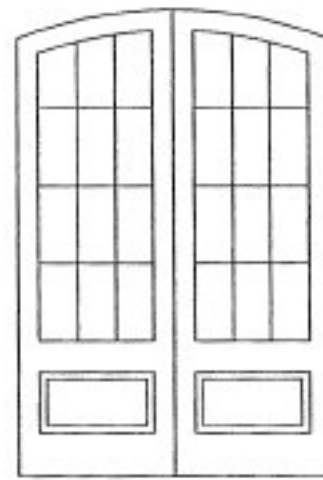

A1612-PR-SG
A5612-PR-IG
A5612-PR-LOW-E

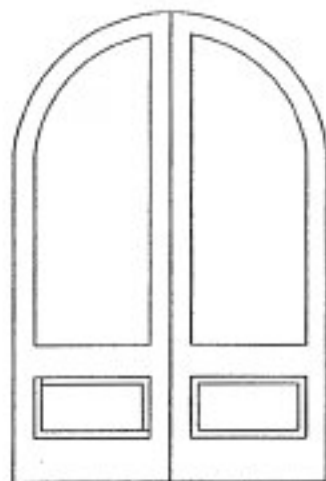

H1601-PR-SG
H5601-PR-IG
H5601-PR-LOW-E

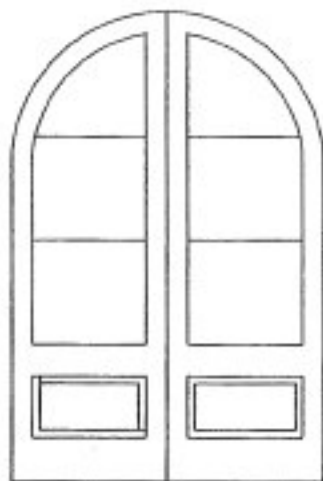

H1603-PR-SG
H5603-PR-IG
H5603-PR-LOW-E

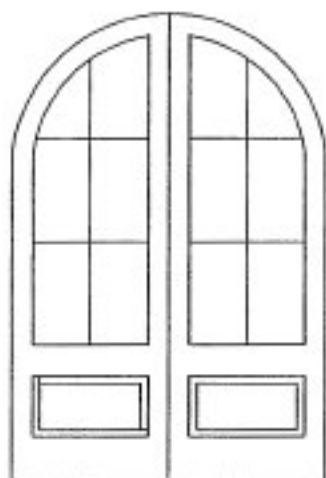

H1606-PR-SG
H5606-PR-IG
H5606-PR-LOW-E

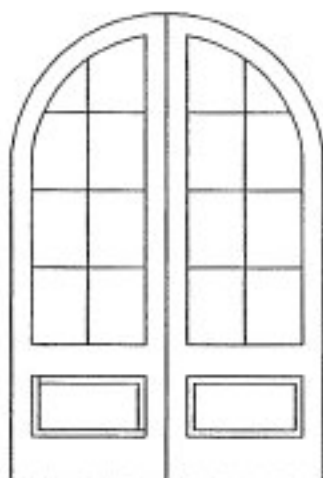

H1608-PR-SG
H5608-PR-IG
H5608-PR-LOW-E

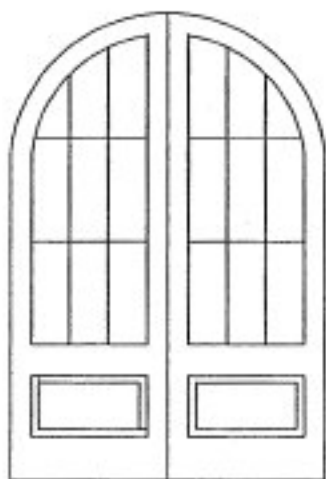

H1609-PR-SG
H5609-PR-IG
H5609-PR-LOW-E

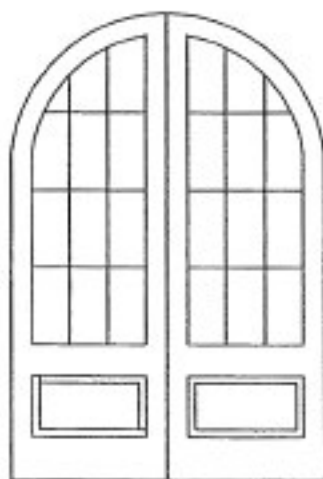

H1612-PR-SG
H5612-PR-IG
H5612-PR-LOW-E

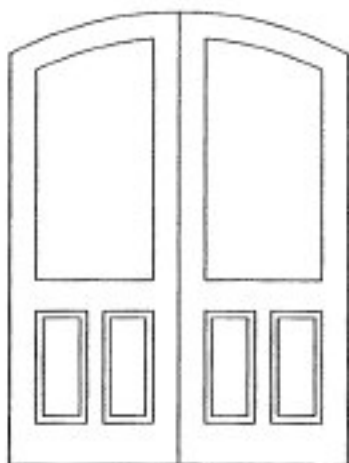

A1701-PR-SG
A5701-PR-IG
A5701-PR-LOW-E

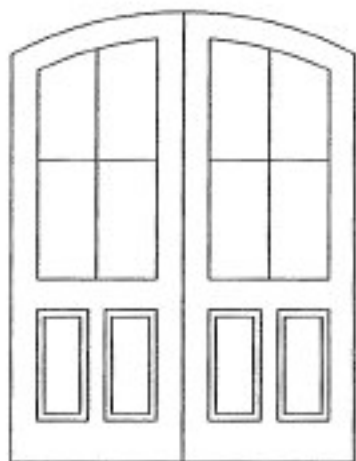

A1704-PR-SG
A5704-PR-IG
A5704-PR-LOW-E

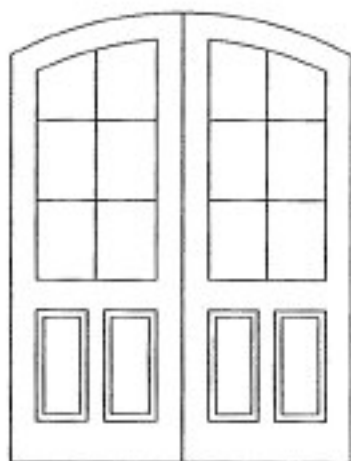

A1706-PR-SG
A5706-PR-IG
A5706-PR-LOW-E

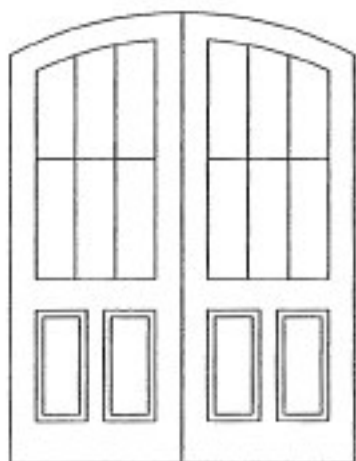

A1708-PR-SG
A5708-PR-IG
A5708-PR-LOW-E

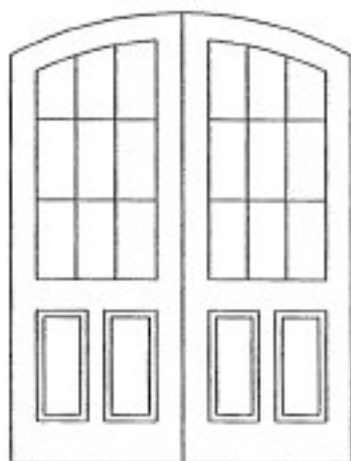

A1709-PR-SG
A5709-PR-IG
A5709-PR-LOW-E

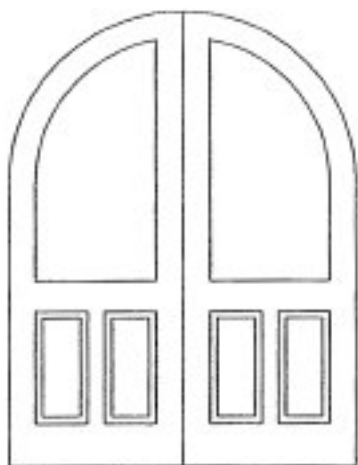

H1801-PR-SG
H5801-PR-IG
H5801-PR-LOW-E

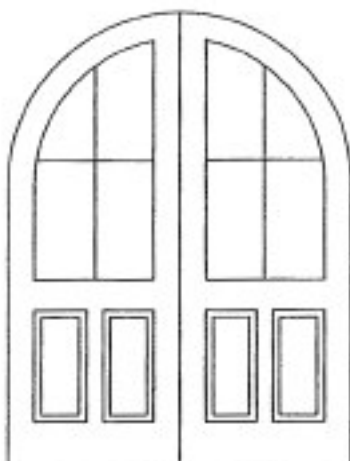

H1801-PR-SG
H5801-PR-IG
H5801-PR-LOW-E

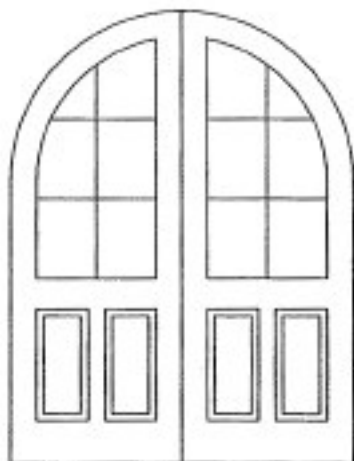

H1801-PR-SG
H5801-PR-IG
H5801-PR-LOW-E

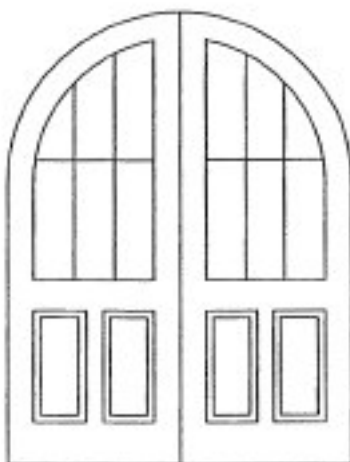

H1801-PR-SG
H5801-PR-IG
H5801-PR-LOW-E

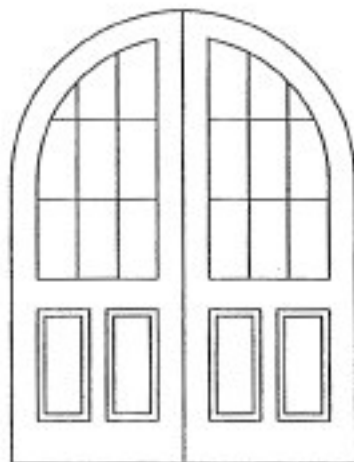

H1801-PR-SG
H5801-PR-IG
H5801-PR-LOW-E

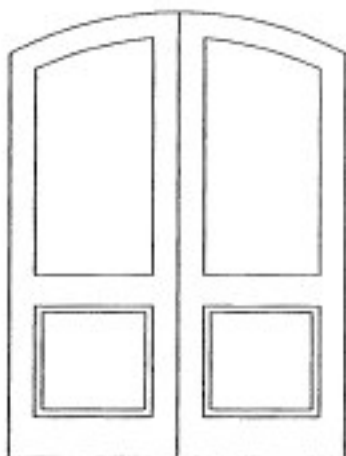

A1801-PR-SG
A5801-PR-IG
A5801-PR-LOW-E

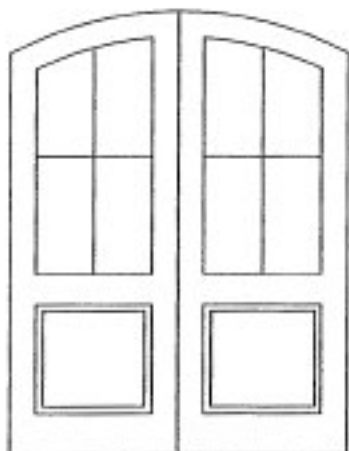

A1804-PR-SG
A5804-PR-IG
A5804-PR-LOW-E

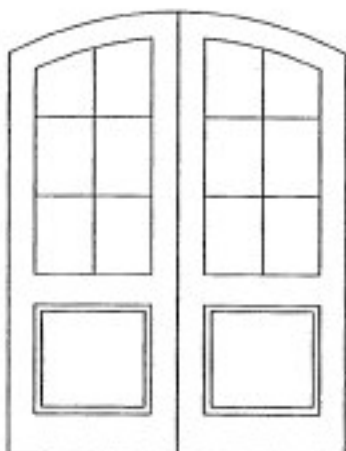

A1806-PR-SG
A5806-PR-IG
A5806-PR-LOW-E

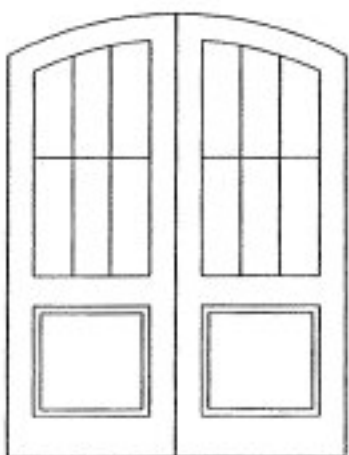

A1805-PR-SG
A5805-PR-IG
A5805-PR-LOW-E

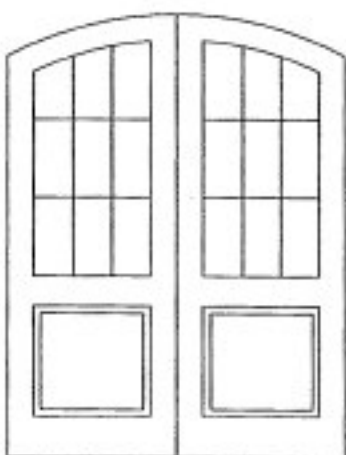

A1809-PR-SG
A5809-PR-IG
A5809-PR-LOW-E

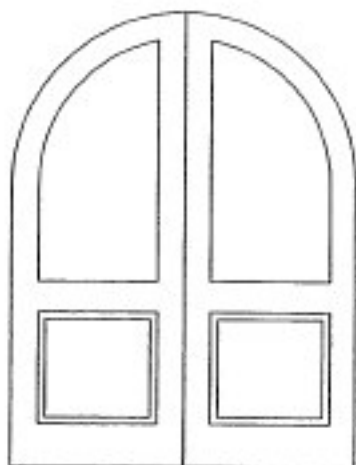

H1801-PR-SG
H5801-PR-IG
H5801-PR-LOW-E

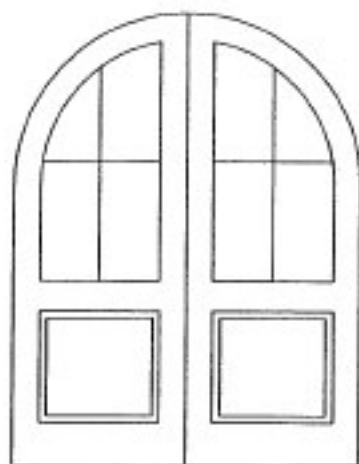

H1801-PR-SG
H5801-PR-IG
H5801-PR-LOW-E

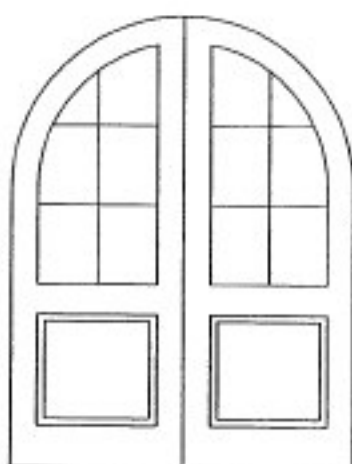

H1801-PR-SG
H5801-PR-IG
H5801-PR-LOW-E

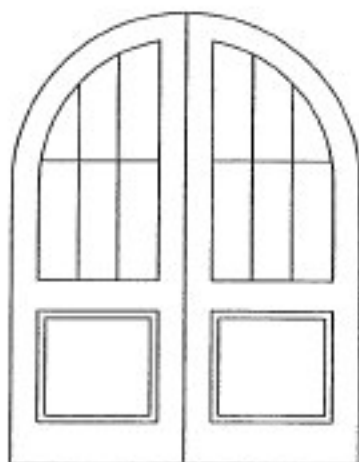

H1801-PR-SG
H5801-PR-IG
H5801-PR-LOW-E

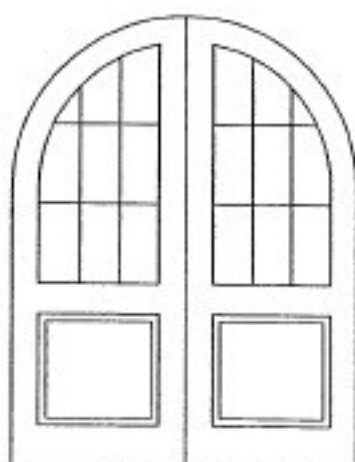

H1801-PR-SG
H5801-PR-IG
H5801-PR-LOW-E

WOOD CHARACTERISTICS AND PROPERTIES

African Mahogany

Color:

The heartwood is initially pink in color, but exposure darkens it to reddish-brown. Colors (light to dark) can vary greatly with different boards.

Grain:

Grain may be straight, but is more often interlocked.

Texture:

It resists denting and marring about as well as white oak or birch. The weight is medium. The wood has high density.

Staining:

African mahogany is reported to take stains well, but variations in colors will be pronounced.

Painting:

The wood is reported to take paint or enamel very well. A primer design to eliminate tannin (red) bleed out is recommended.

Weathering Properties:

African mahogany is reported to have very good weathering qualities which make a good choice for doors.

Alder

Color:

The heartwood, which is indistinct from the sap wood, is whitish when first cut, but changes color upon exposure to light brown.

Grain:

Alder has been described as 'pleasing' in appearance, with grain that is typically straight and subdued. Although the color has often been described as delicate, the wood is without any outstanding figure.

Texture:

Texture is typically fine and even, and is close.

Staining:

The uniform, small pore structure and color consistency of alder are reported to allow it to accept a variety of commercially available stains, and can be stained to match other cabinet woods.

Painting:

The wood is reported to take paint or enamel very well.

Weathering Properties:

Alder does not have ratings for exterior use.

Knotty Alder

Color

The heartwood, which is indistinct from the sap wood, is whitish when first cut, but changes color upon exposure to light brown.

Grain:

Same as Alder Texture Texture is typically fine and even, but it has tight open knots

Staining:

The uniform, small pore structure and color consistency of alder are reported to allow it to accept a variety of commercially available stains, and can be stained to match other cabinet woods. The knotty grade is good for distressing.

Painting:

The wood is not to be used for painting due to the exposed knots.

Weathering Properties:
Alder does not have ratings for exterior use.

Hard maple

Color:
Hard Maple is white in color.
Grain:
Grain is typically straight, but it can also be curly or wavy.
Texture:
The wood has a very fine and even texture. It is a very hard wood and will take wear well.
Staining:
The wood is reported to stain satisfactorily but unevenly.
Painting:
The wood is reported to take paint or enamel very well.
Weathering Properties:
Hard Maple does not have ratings for exterior use.

Honduras Mahogany

Color:
Mahogany varies considerably in color maturing into a deep rich red or brown color with age. Very consistent colors, but will have small worm holes.
Grain:
The grain is straight to wavy, or curly.
Texture:
The texture is fine or medium to course, and uniform.
Weathering Properties:
Mahogany is reported to have very good weathering qualities which make a very good choice for doors.
Staining:
The wood takes stain well. **Painting** The wood is reported to take paint or enamel very well. A primer designed to eliminate tannin (red) bleed out is recommended.

Poplar

Color:
The heartwood is described as pale-olive green to brown, or clear yellow to tan or greenish brown. It usually has blue-colored streaks or shades of purple, dark green, blue and black.
Grain:
The wood is straight grained, occasionally with an attractive blister figure.
Texture:
Texture is typically fine and even.
Staining:
Staining characteristics are reported to be good. Different colored streaks which are normally found in the heartwood will interfere with stain finish.
Painting:
The wood takes paint very well.
Exterior durability:
Very little. Has great tendency to rot in exterior use if not properly and continuously sealed from elements. Not recommended for exterior use. Excellent wood for interior use paints well.

Red oak

Color: The heartwood is pinkish to light reddish brown or light brown. The wood may also show a pronounced cast of flesh color.
Grain:

The grain is usually straight and open. Plain sawn lumber usually exhibits a plumed or flared grain appearance, while rift sawn members show a tighter grain pattern and low figuring. Quarter sawn red oak boards often have a flake pattern which is sometimes referred to as tiger rays or butterflies. Grain and color variation is usually pronounced and is dependent upon the origin of the wood and the growing season in that locality.

Texture:

The texture is medium to course, and uniform. Hardness is rated as medium, and weight is high.

Staining:

The wood has good staining qualities. Large pores tend to produce strong contrast in staining. Consistent use of a batch of either quarter sawn or flat sawn stock for a given project is recommended since prominent rays can render seams in edge-glued stock very obvious. Red oak is regarded as one of the most beautiful woods to work with because of its grain pattern and character. Smaller rays give the timber a plainer figure than white oak, and its open pores make it less water-tight.

Painting:

The large pores of this wood present a challenge for a smooth paint finish.

Weathering Properties:

Red Oak has good weathering qualities. Slightly less than white oak.

Soft maple

Color:

The heartwood is light brown and may occasionally show a grayish or greenish tinge or a faint purplish hue.

Grain:

Straight but occasionally curly or wavy. The wood is described as close-grained.

Texture:

The wood is fine textured, and is medium hard.

Staining:

This wood has poor to medium staining qualities. It has a great tendency to stain unevenly.

Painting:

Soft Maple has excellent painting characteristics.

Finishing Recommendations

Finishing Options

Because Vision Products doors are crafted with only the finest materials, you can choose from a wide variety of stain or paint possibilities. Paint dealers have a broad selection of color chips on hand to demonstrate the look you can achieve when staining fine Vision Products doors.

If you choose paint instead of stain, you can apply either oil-base or latex resin-base paints over an oilbase primer. However, take care in following the finishing instructions provided. Also, be sure to evaluate the conditions your Vision door must endure, such as direct exposure to severe climates, before deciding on the specific finish to use.

Handling

- *Do not walk on any door units. Some units contain glass.
- *Avoid dragging doors across one another and keep doors clean. *Store flat on a level surface in a dry, well-ventilated building.
- *Doors should be conditioned to average prevailing relative humidity of the locality before hanging.
- *Doors should not be subject to extreme or rapid changes in heat or humidity. Avoid sudden changes such as forced heat to dry out a building.
- *If the doors are to be stored on the job site, all ends and edges must be sealed with an effective quality oilbase sealer in order to prevent undue moisture absorption.

Preparation for Finishing

- *Before applying the first coat of finish, sand the entire surface lightly with 5/0 sandpaper (180 grit). This is to remove fingerprints and handling marks.
- *Adjust or align components (if necessary) before finishing. Wood panels "float" and may be knocked into alignment with a wood block and hammer. Be careful not to damage door.
- *Clean door thoroughly after sanding with a cloth to remove all dust or foreign material. However, avoid using caustic or abrasive cleaners.
- *Hang door before finishing, then remove to finish properly.
- *All surfaces of the door must be properly finished. The edges (top, bottom and sides) should be coated with each and every coat of finish that is applied to the exterior surface of the door. Doors must be dry before finishing.
- *On doors that are glazed with clear glass, the finish used should be flowed from the wood slightly onto the glass. This will provide assurance against water leakage and protect the glazing "putty" from drying out.

Exterior Finishing

Stain-and-Clear Finish

The first coat should be a stain-and-sealer, a combination of stain and sealer which colors the door and seals the surface. It is available in a wide range of colors. The stain-and-sealer should have an alkyd-resin base. Under no circumstances should a lacquer-based toner or any other lacquer-based finish be used on exterior doors.

The second and third coat (two top coats minimum) may be solvent-borne (oil-base, alkyd resin-base, polyurethane resin-base) or a water-borne (latex resinbase) clear finish.

The advantages and disadvantages of solvent-borne vs. water-borne clear finishes are as follows:

Solvent-Borne Advantages: Faster drying, harder and more water-resistant. May be applied under variable weather conditions.

Disadvantages: Subject to ultra-violet degradation and not as flexible or durable as water-borne clear finish.

Water-Borne Advantages: Very flexible, greater ultraviolet resistance, and good exterior durability. *Disadvantages:* Cannot be applied below 50 degrees F., long drying period required, and may not fully cure for several weeks. Water-sensitive until cure is complete. **Note:** Do not sand between coats of latex clear. All stain-and-clear finishes will perform measurably better if protected from the direct effects of sunlight and weathering, and refinishing will not be required as frequently.

Paint Finish

Either oil-base or latex resin-base exterior grade paints may be used with success on panel doors. Oil-base paints offer more resistance to the passage of water (liquid and vapor) than latex resin-base paints, but the latter have better durability and color retention.

Doors should be sealed with a good quality oil-base primer followed by two topcoats of either an oil-base or latex resin-base paint. Of course, both primer and top coat should be made by the same manufacturer and be designed to be used as a combination.

Note: Where possible exposure to direct sun or rain is a factor, doors should be sealed with a premium quality oil-base primer followed by two top coats of a premium quality oil-base paint.

Caution

Vision Products cannot evaluate all the available paints and stains, nor the customers' specific application requirements. Your paint dealer should know of suitable finish systems that give satisfactory results in your region. It is highly recommended that top quality finishes be selected, and the application instructions on the container be followed explicitly.

Fitting and Hanging

*When hanging door, allow adequate clearance for swelling of door or frame in damp weather. Allow approximately 3/18" clearance for swelling when the door is installed in fully dry conditions. Jambs must be plumb.

*Do not cut panel doors down in height by more than 2" (13.16" maximum from top). Care should be taken in cutting panel doors down in width to avoid exposing engineered components. Use sharp fine tooth saw for trimming ends of doors.

*Caution must be used to avoid impairing the strength of the door when fitting for locks. Allow at least 1" of wood back of mortise.

*Use three hinges on doors up to 7' in height and four hinges on doors over 7'. Hinges must be set in a straight line to prevent distortion.

*Jambs and stops must be set square and plumb.

*For best performance, any exterior door should be installed under an overhang or with protection. If an overhang is not feasible, finishing the door in a light color will prevent excess heat build-up in the door.

*Immediately after cutting and fitting (before hanging), seal all cut surfaces and ends of door with an effective quality sealer. See exterior finishing recommendation for complete instructions.

*Prior to exterior exposure, doors should be finished with complete finish system.

*To minimize heat loss and save energy, use weather stripping.

Maintenance

Your Vision Products door has been handcrafted to last for years to come. But, like any fine piece of furniture, its finish will require some simple, periodic maintenance to keep it looking great and provide proper protection against the elements. **Regular finish maintenance is also a requirement of the warranty that's included with every Vision door.**

Here are some signs to watch for. They indicate that it's time for some simple, easy-to-perform maintenance:

1. Hairline cracks in the top coat of finish.
2. Changes in the color of the finish.
3. Changes in the texture of the finish (flaking, scaling)
4. Dullness or chalkiness in the finish.

If you live in a severe climate or your entry receives a lot of direct sunlight from a southern or western exposure, you'll want to examine the door's finish often. Depending on the conditions, you may also need to refinish the door more frequently.

LIMITED WARRANTY

Slab-LVL- Doors

Vision Products Industries, Ltd. (VPI) warrants, subject to the condition and restrictions stated below, that the VPI wood doors using engineered stiles when properly installed and maintained, will be free from manufacturing defects, including panel splits, under normal conditions of ordinary wear, for two years. This warranty applies to doors properly sealed, finished and hung in a location protected from exposure to direct sun or rain under normal conditions. This limited warranty is made and extends only to the original purchaser of the door (whether a distributor, dealer, contractor or owner) and the owner occupying single family residence at the time of the initial installation. It may not be assigned or transferred and shall not extend to subsequent owners. This warranty excludes the following characteristics: damage caused by attempts other than VPI to repair the door, natural variations in the color or texture of the door, failure to seal the door properly (all edges must be sealed immediately after hanging), and/or damage caused by improper handling or storage.

INSULATED GLASS WARRANTY

VPI will warrant TruSeal (swiggle) insulated glass glazed into VPI wood doors for twenty years the date stamped on the glass. Under normal conditions, VPI warrants there will be no material obstruction of vision through the unit due to accumulation of dust, moisture, or film formation on the internal surface of the glass caused by failure of the units insulating edge seal due to defects in material or workmanship. This warranty specifically excludes defects or damage attributable to installation, normal weathering atmosphere pollutants, mildew buildup, misuse, abuse, glass breakage, installation into a sloped glazing application, refrigeration system, solar collector, swimming pool or spa enclosure, application subject to abnormal stresses and excessive temperature differentials, settlement of the building, failure of the structure, the Owners failure to provide reasonable and necessary maintenance of the product, earthquakes and/or other acts of God.

Any claim requires an inspection by an authorized agent of VPI. If it is determined that the claim is valid in accordance with the provisions of this warranty, VPI agrees, as its option, to either refund the original selling price of the door or replace the door, as originally sold by VPI!, without charge, to the shipping point nearest the point of purchase. The warranty on the replacement unit shall extend only for the balance of the warranty period applicable to the original unit. This warranty does not cover any charges for labor, installation, finishing or any other incidental costs related thereto of either the original or replacement product or any replacement part.